



perforated metal



About Fielden

What We Do

Fielden process a variety of materials, including steel, stainless steel, aluminium, brass, copper and some plastics in our Christchurch factory. With a client base covering a diverse range of industries, we have experience in manufacturing a broad range of products. Our team possess an array of metal working skills and experience in mechanical engineering.

We can work with you to develop your product, offering a design and prototyping service using the latest 3D modelling and analysis software. This is integrated with CAM software that commands our machines and provides a seamless service from concept design to finished components.

At Fielden we run a full Enterprise Resource Planning system (ERP). This integrated management system logs all projects and provides accurate details on cost, lead times, delivery and quality control at all stages of manufacture. The ERP tools are also being used to support our ongoing commitment to quality and environmental management systems.

The factory is increasingly equipped with computer controlled machines, including an integrated robotic work cell that can operate unmanned, reducing labour costs by over 80%. These are complemented with a range of flexible turret punches, press brakes, laser cutter, guillotines & mechanical presses that our technicians operate to generate engineering and architectural sheetmetal solutions. We offer MIG and TIG welding for a variety of light fabrication offerings. All items can be easily finished through our degreasing and powder coating facilities.

Our History

Fielden & Sons was founded in 1963 by brothers Ross and Norm Fielden who earned an excellent reputation for the manufacture of sheetmetal components. The company was taken over by Nigel Maxey in 2006 who made the commitment to run modern machines and state-of-the-art management systems. The operation has continued to grow with the acquisition of Maxim Filing systems in 2010 and Jackson Sheetmetal in 2016.

Jackson's was established in 1978 by Ken and Pam Jackson and built a name for quality workmanship in custom products and perforated sheet and coil, a perfect compliment to the services of Fielden Metalworks.

Our staff are a talented and multi-tasking team with experience in all aspects of sheet metal manufacture. All are committed to high quality production and meeting your time frame expectations.

Please call us to discuss your project needs.

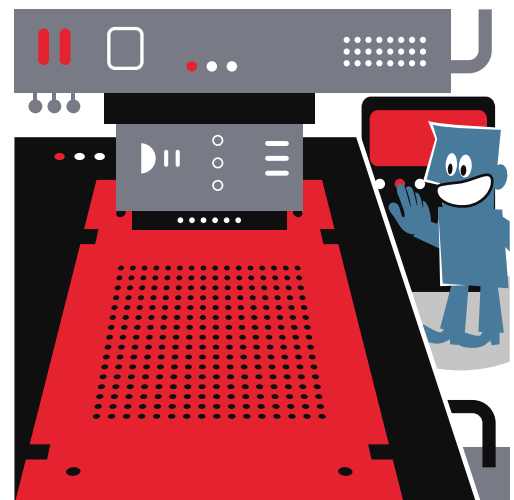

Contents

<i>Our Machines</i>	4
<i>Other Services</i>	5
<i>Perforated Metal Functions</i>	6
<i>Perforation Types</i>	7
<i>Selecting a Perforation</i>	9
<i>Materials</i>	10
<i>Perforation Codes</i>	11
<i>Perforated Coil</i>	12
<i>Perforated Sheet</i>	
<i>Round Holes</i>	16
<i>Square Holes</i>	23
<i>Rectangular Slots</i>	29
<i>Obround Slots</i>	33
<i>Hexagonal</i>	37
<i>Dimples</i>	39
<i>Decorative</i>	42
<i>Custom Perforations</i>	50
<i>Special Patterns</i>	51
<i>Picture Perforations</i>	52
<i>Reference Tables</i>	
<i>Table of Gauges and Weights</i>	54
<i>Contact Us</i>	56

Our Machines



Fielden currently runs two Amada CNC Turret Punch Presses, one with an auto feeder allowing non-stop machine running without human intervention to increase cost effectiveness. The second Amada includes a laser for sheets to be laser cut and punched on the same machine in the same programme.



Also in our facility, is a Murata C2000 Turret Punch Press as a reliable workhorse for lighter jobs, as well as a 50 tonne Murata C5000 Magnum Turret Punch Press which provides reliability and high punching power for up to 8mm steel plate.



We also operate a coil perforating line allowing long runs of coil to be decoiled, punched and recoiled. This operation is very efficient for long-run coil aluminium, copper, brass and a range of steels.

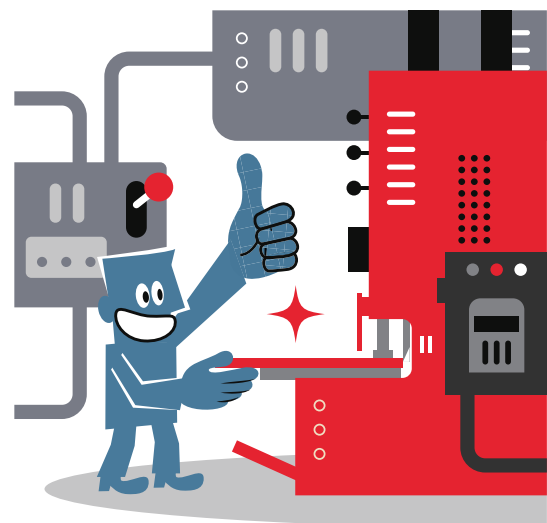

Other Services

❖ TIG/MIG/Spot Welding and Fabrication

- ❖ We can offer a wide range of fabrication services to combine perforated sheet metal in a larger project with other steelwork.

❖ Laser cutting

- ❖ Using the combination turret punch and laser cutter we have the versatility to produce your product efficiently.

❖ Folding

- ❖ With our range of CNC and robotic press brakes we can meet your sheet metal folding requirements with a capacity of up to 6m lengths.

❖ Powder Coating

- ❖ We can provide in-house powder coating for your sheet metal or other fabricated products, reducing lead time.

❖ High Volume Bracket Manufacturing

- ❖ Our power presses allow a cost effective method for producing large quantities of brackets which require multiple operations of punching and folding in a single automated machine.





Perforation Uses

Acoustic Control

Perforated metal is your perfect partner for soundproofing and for reducing acoustic emissions as well as a supporting structure for other less rigid sound-insulating materials. A number of sound baffle designs use perforated metal of specific hole size and open area that relate to the sound frequencies to be eliminated.

Light Screening & Shading

Looking for durable screening applications with extra aesthetic touch, then choose perforated metal. A wide range of powder-coat colours can be applied to generate vibrant designs that can enhance the appearance of buildings while providing shade.

Heat Dissipation

Components made from perforated metal play a valuable role in thermal controls, for heat dissipation in cooling systems, hot-air ventilators or complex heating units. The combination of useful function with appealing aesthetics through unique patterning offers a nice complement to the function of products.

Protection & Guarding

Guarding of machinery or hot surfaces can be easily produced with perforated metal to prevent injury while permitting clear vision of the equipment or heat to pass through.

Filtration, Sieving & Screening

The perforation and open area can be specified exactly, making perforated sheet ideal for filtering, separating, or sorting materials. The open area can be varied in a number of ways to affect the flow rate, sorted size, etc. resulting in high accuracy.

Anti-Skid Walk Surfaces

Industrial floorings made from perforated & stamped metal provide great grip properties to ensure safe access to work areas. Especially in conditions with high exposure to moisture or dust, etc.

Weight Reduction

Reducing weight is very important in manufacture of transport equipment. Perforated metal is the ideal way to meet this requirement. In addition, folding or dimpling perforated metal provides a stiffening effect so that the components are not weakened by the removal of material.

Electrical Shrouding

Perforated metal is often used to enclose electrical components to attenuate the emitted EMI /RFT radiation and to allow ventilation at the same time. This is the best method for preventing radio interference in electronic products.

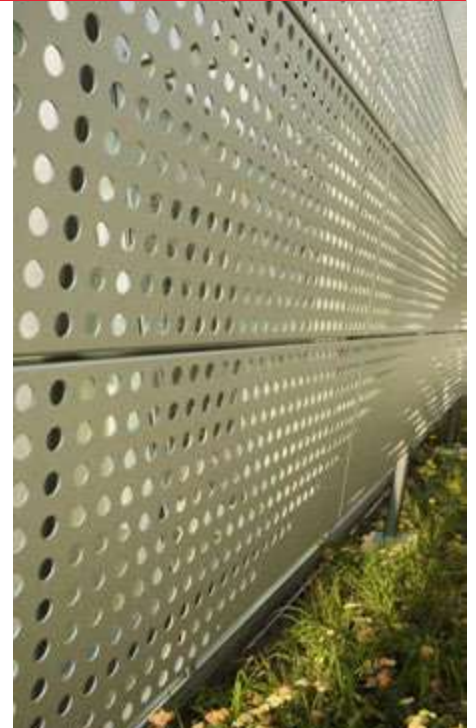

Perforation Types

Open area is a measure used to reflect the percentage of perforated area to total sheet area. These formulae below are used to calculate the open area for many common patterns. For unusual patterns and/or shapes, the open area can be found by calculating the total hole for a set area and dividing it by the total set area.

Round Perforations

Rectangular

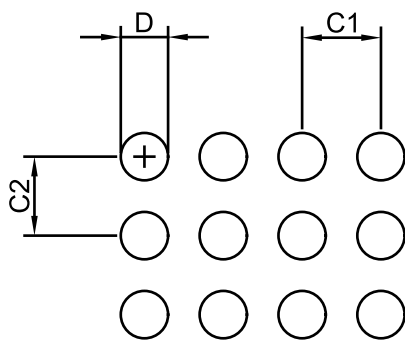

$$\text{Open Area \%} = \frac{\frac{\pi}{4} D^2}{C_1 \times C_2} \times 100$$

Staggered

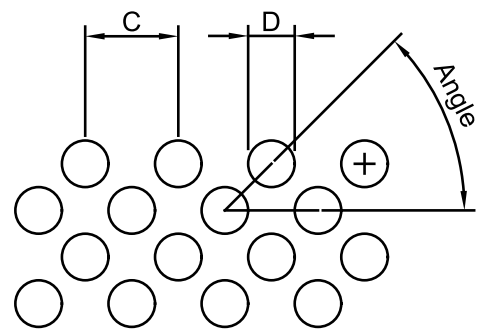

$$\text{Open Area \%} = \frac{\pi D^2}{2C_1^2 \tan(\theta)} \times 100$$

Square Perforations

Rectangular

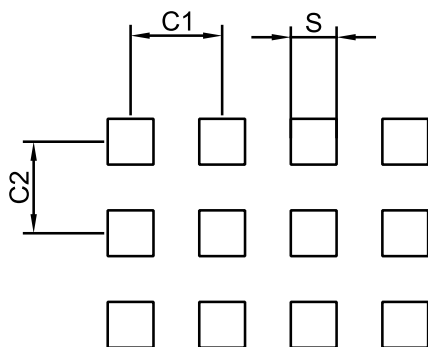

$$\text{Open Area \%} = \frac{S^2}{C_1 \times C_2} \times 100$$

Staggered

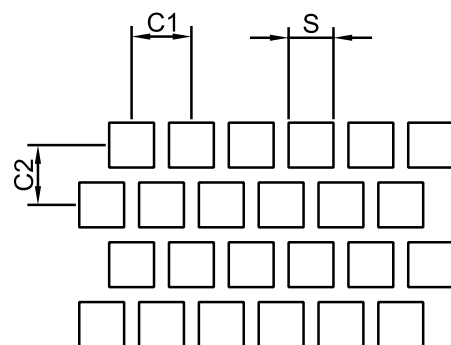

$$\text{Open Area \%} = \frac{S^2}{C_1 \times C_2} \times 100$$

Slots – Rectangular and Obround

Rectangular

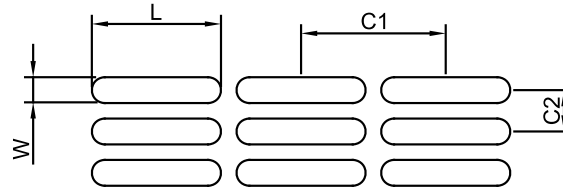

Side Staggered

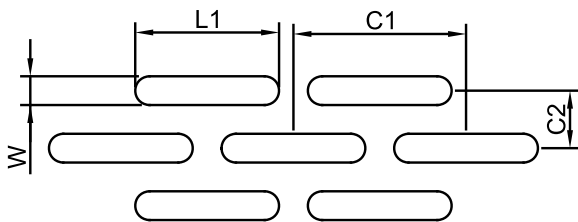

End Staggered

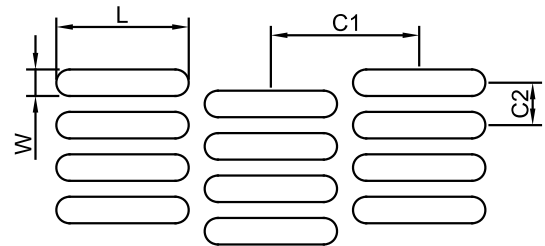

For rectangular holes:

$$\text{Open Area \%} = \frac{W \times L}{C_1 \times C_2} \times 100$$

For obround holes:

$$\text{Open Area \%} = \frac{WL - 0.215W^2}{C_1 \times C_2} \times 100$$

Hexagonal - Honeycomb

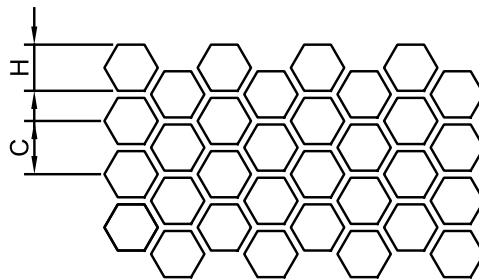

$$\text{Open Area \%} = \frac{H^2}{C^2} \times 100$$

Selecting a Perforation

When selecting a perforation, there are a few considerations that are important for choosing the hole shape, pattern and material.

Things to keep in mind:

- ❖ Final application of the perforated metal eg: acoustic control, screening, guarding, etc.
- ❖ As a general guideline the hole diameter for punching steel and aluminium should be no less than the material thickness. For stainless it should be no less than 1.5 times the sheet thickness.
- ❖ 5 to 100mm border margin - if the border margins are important for your design please make sure you contact us early on in your design process to make sure your requirements can be met with the perforation you desire.
- ❖ Generally perforations with larger hole sizes cost less due to reduced machine time.
- ❖ The minimum bar thickness (material left between holes) should generally be no less than the material thickness. However there are instances where bar thicknesses smaller than this can be accommodated.
- ❖ Typical sheet size is 2400mm x 1200mm, or 2438mm x 1219mm.
- ❖ The punching direction is normally along the longest sheet dimension.
- ❖ Patterns are displayed in this catalogue with the width of the page representing the width of the perforated sheet. However, these patterns can often be run at 90° to what is illustrated on request.
- ❖ If your requirements are not listed in this catalogue, please contact us to discuss the options as not all patterns are displayed in this catalogue.

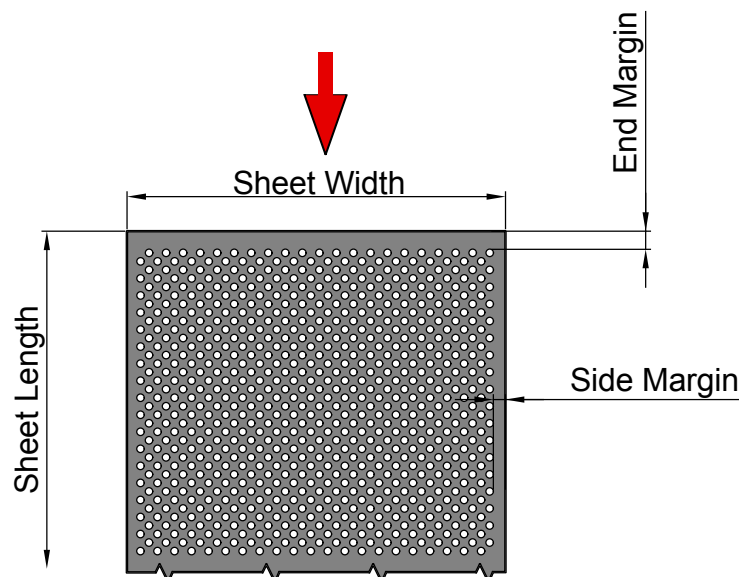

Give us a call to help you with your selection – we have years of proven experience in producing perforated sheet metal and can assist you throughout all stages of the process.



Materials

❖ Cold Rolled Steel

- ❖ Cost efficient material which provides a polished finish with no scale. It requires a coating to be applied for corrosion resistance. Hot rolled is also available on request.

❖ Electrogalvanised Steel

- ❖ Electrogalvanised steel is a zinc coated steel which is applied using electroplating rather than the more typical hot dip method. This results in a thinner, but more uniform zinc coating and therefore more suited for aesthetic applications and is not recommended for outdoor applications.

❖ Galvanised Steel

- ❖ Hot dip galvanised steel has a thick sacrificial zinc coating and is a standard for exterior application. The look of this steel is a more spangled finish than electrogalv.

❖ 5005 and 5052 Aluminium

- ❖ 5005 is a medium strength aluminium alloy with good corrosion resistance and weldability. Both are used for architectural applications, whilst 5052 has an increased tensile strength and a slightly higher corrosion resistance due to a higher concentration of magnesium and chromium.

❖ 304 and 316 Stainless Steel

- ❖ 304 is the most common stainless steel alloy, which is used for a variety of applications and is readily formable and weldable. 316 is similar to 304, but more corrosion resistant due to the addition of Molybdenum. It is therefore a better choice for coastal environments.

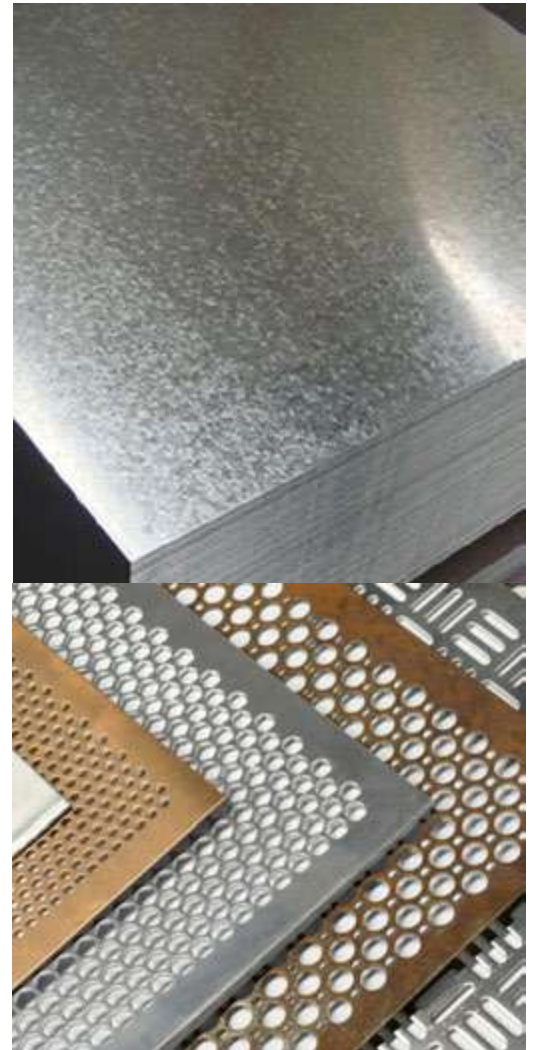

We can also process the zinc/aluminium alloy **Zincalume®** and **Colorsteel®** products on request. Material is only standard in coil.

Copper, brass, other metals and some plastics can also be processed.

Advisory:

Due to the hardness and work hardening nature of stainless steel it is a difficult material to punch. Therefore the number of patterns available is limited. If you require stainless for your application then contact us for any customisation options.

Perforation Codes

In NZ the defacto standard is to use P codes to denote the perforation pattern. This is a code system which assigns an arbitrary P number to a certain pattern. Different manufacturers may use the same code, but they may not be exactly the same pattern. We have our own coding system, as explained below. For patterns with existing P codes, these patterns will use both Fielden Perforation Codes (FPC) and the legacy P codes.

Fielden Perforation Codes

Perforated sheet metal codes are defined by a pattern code with an appended material code.

The pattern code is formatted as follows:

(Shape)(Dimension)(Orientation)(Open Area%)

1	2	3	4	5	6	7
Hole Shape	Hole Dimension			Hole Orientation	Open Area	
Round	R	Hexagon	H	to 1 D.P.	Triangle (60°)	A
Square	S	Triangle	T	↑	Triangle (45°)	B
Obround	O	Dimple	D		Triangle (custom°)	C
Rectangle	C	Louvre	L	↓	Square/Rectangular	S
Rectangle Radius Corner	Q	OSH	Z		Side Staggered	G
Diamond	V	Special	X		End Staggered	E

R019A45

For a round hole perforation with 1.9mm diameter, 60 stagger orientation and an open area of 45%

NB: For coil perforations, all codes have the character 'C' suffix eg. R019A45C

The material code for stock sheets is formatted as follows:

(Material Type)(Sheet Thickness)(Sheet Size)

8	9	10	11
Material Type	Material Thickness		Sheet Size
Cold Rolled MS	C	Coloursteel	R
Hot Rolled MS	H	Alu 5005	A
Galvanised MS	G	304 Stainless	S
Electrogalv MS	E	316 Stainless	T
Zincalume	Z		

R019A45-G12A

For a Galvanised 2.4x1.2m sheet of 1.2mm thickness



Perforated Coil

These coil perforations can be run at widths up to 1220mm wide.

Maximum thickness for aluminium of 3.0mm

Maximum thickness for cold rolled and coloursteel of 1.5mm

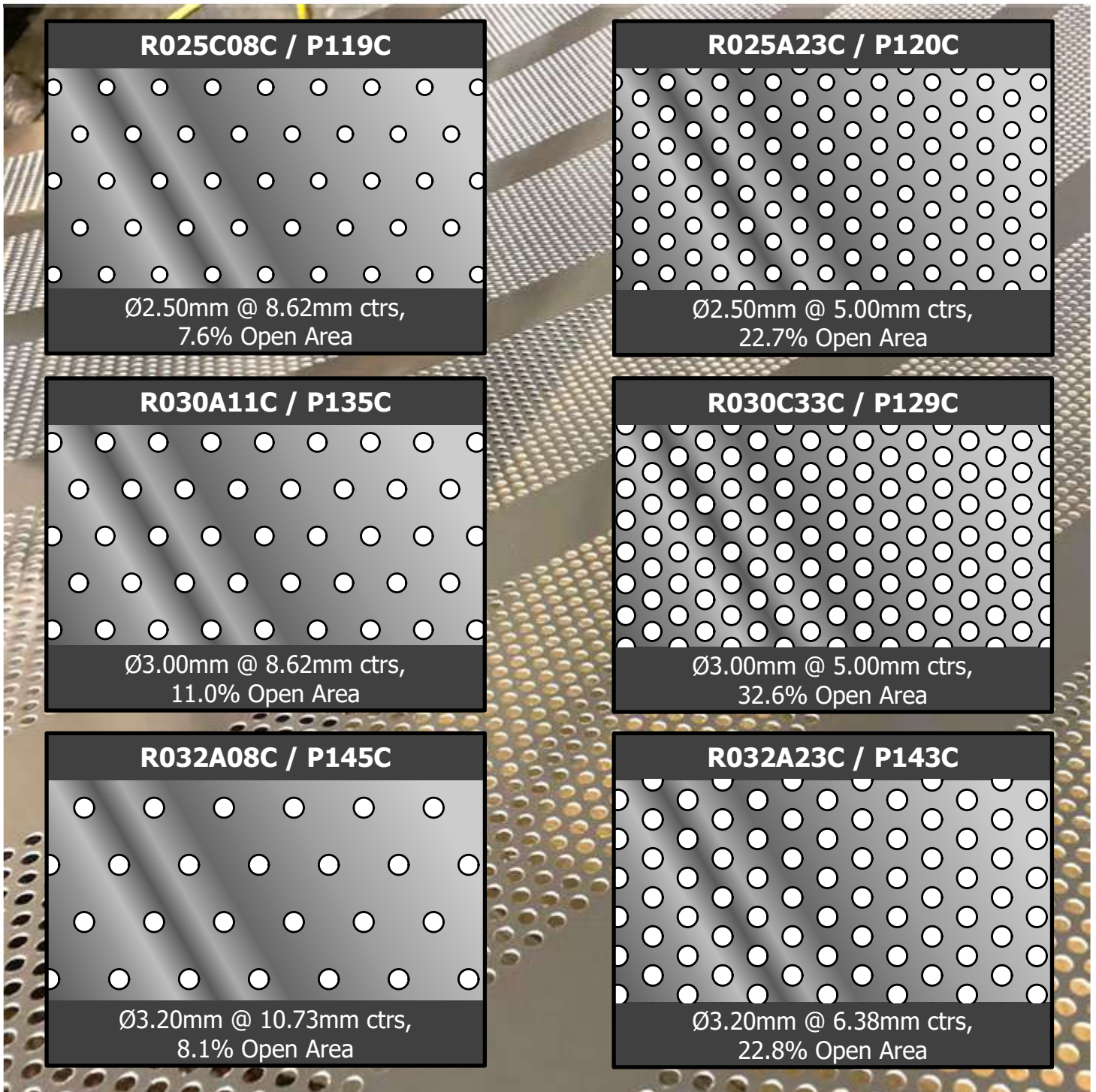

R025C08C / P119C

Ø2.50mm @ 8.62mm ctrs,
7.6% Open Area

R025A23C / P120C

Ø2.50mm @ 5.00mm ctrs,
22.7% Open Area

R030A11C / P135C

Ø3.00mm @ 8.62mm ctrs,
11.0% Open Area

R030C33C / P129C

Ø3.00mm @ 5.00mm ctrs,
32.6% Open Area

R032A08C / P145C

Ø3.20mm @ 10.73mm ctrs,
8.1% Open Area

R032A23C / P143C

Ø3.20mm @ 6.38mm ctrs,
22.8% Open Area



Perforated Coil

These coil perforations can be run at widths up to 1220mm wide.

Maximum thickness for aluminium of 3.0mm

Maximum thickness for cold rolled and coloursteel of 1.5mm

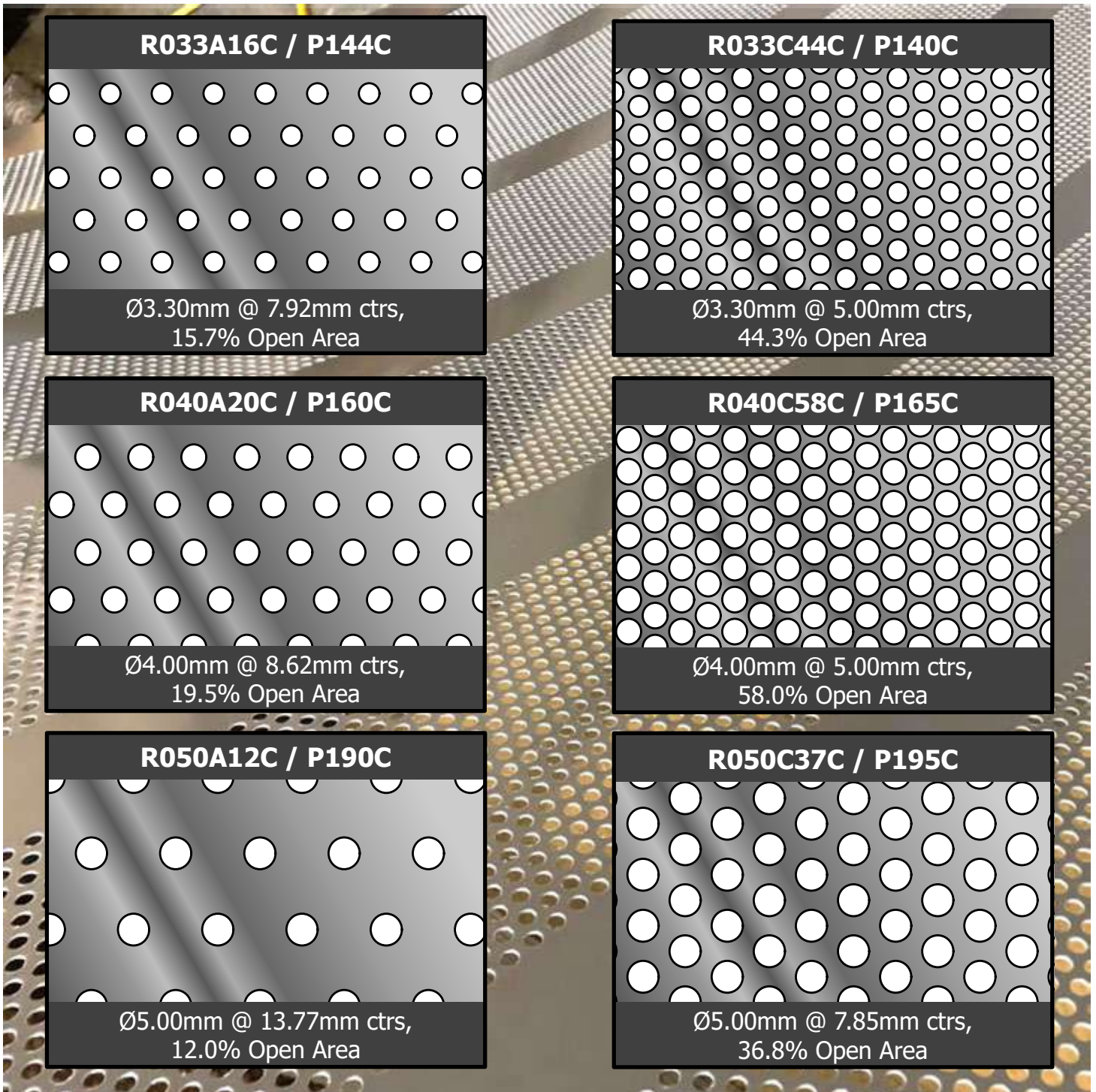

R033A16C / P144C

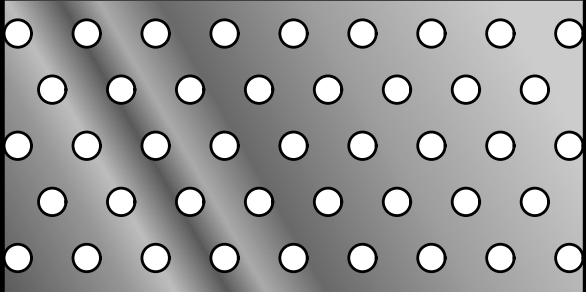

Ø3.30mm @ 7.92mm ctrs,
15.7% Open Area

R033C44C / P140C

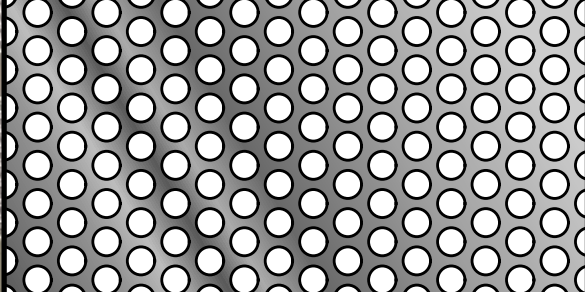

Ø3.30mm @ 5.00mm ctrs,
44.3% Open Area

R040A20C / P160C

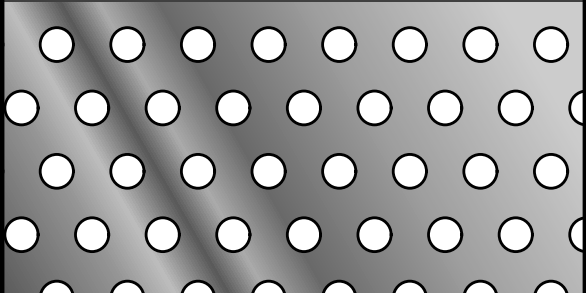

Ø4.00mm @ 8.62mm ctrs,
19.5% Open Area

R040C58C / P165C

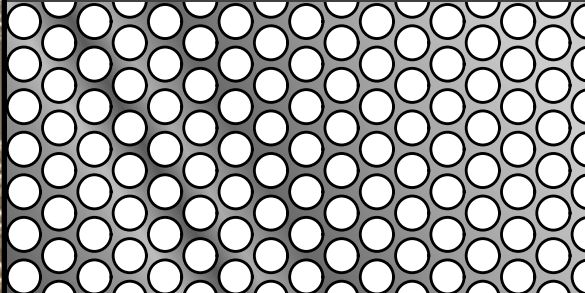

Ø4.00mm @ 5.00mm ctrs,
58.0% Open Area

R050A12C / P190C

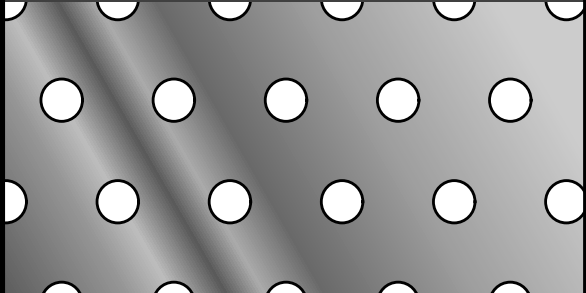

Ø5.00mm @ 13.77mm ctrs,
12.0% Open Area

R050C37C / P195C

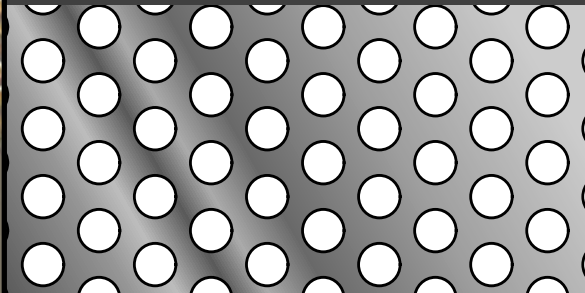

Ø5.00mm @ 7.85mm ctrs,
36.8% Open Area



Perforated Coil

These coil perforations can be run at widths up to 1220mm wide.

Maximum thickness for aluminium of 3.0mm

Maximum thickness for cold rolled and coloursteel of 1.5mm

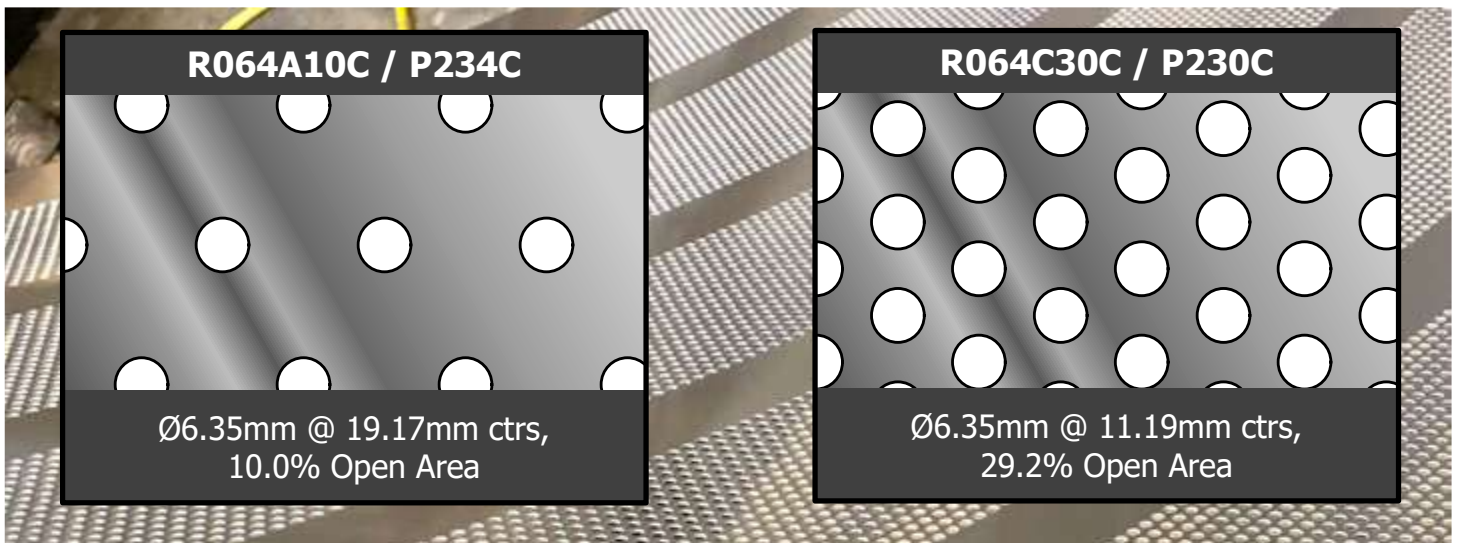

R064A10C / P234C

Ø6.35mm @ 19.17mm ctrs,
10.0% Open Area

R064C30C / P230C

Ø6.35mm @ 11.19mm ctrs,
29.2% Open Area

The coil perforation below can be run at widths up to 650mm wide.

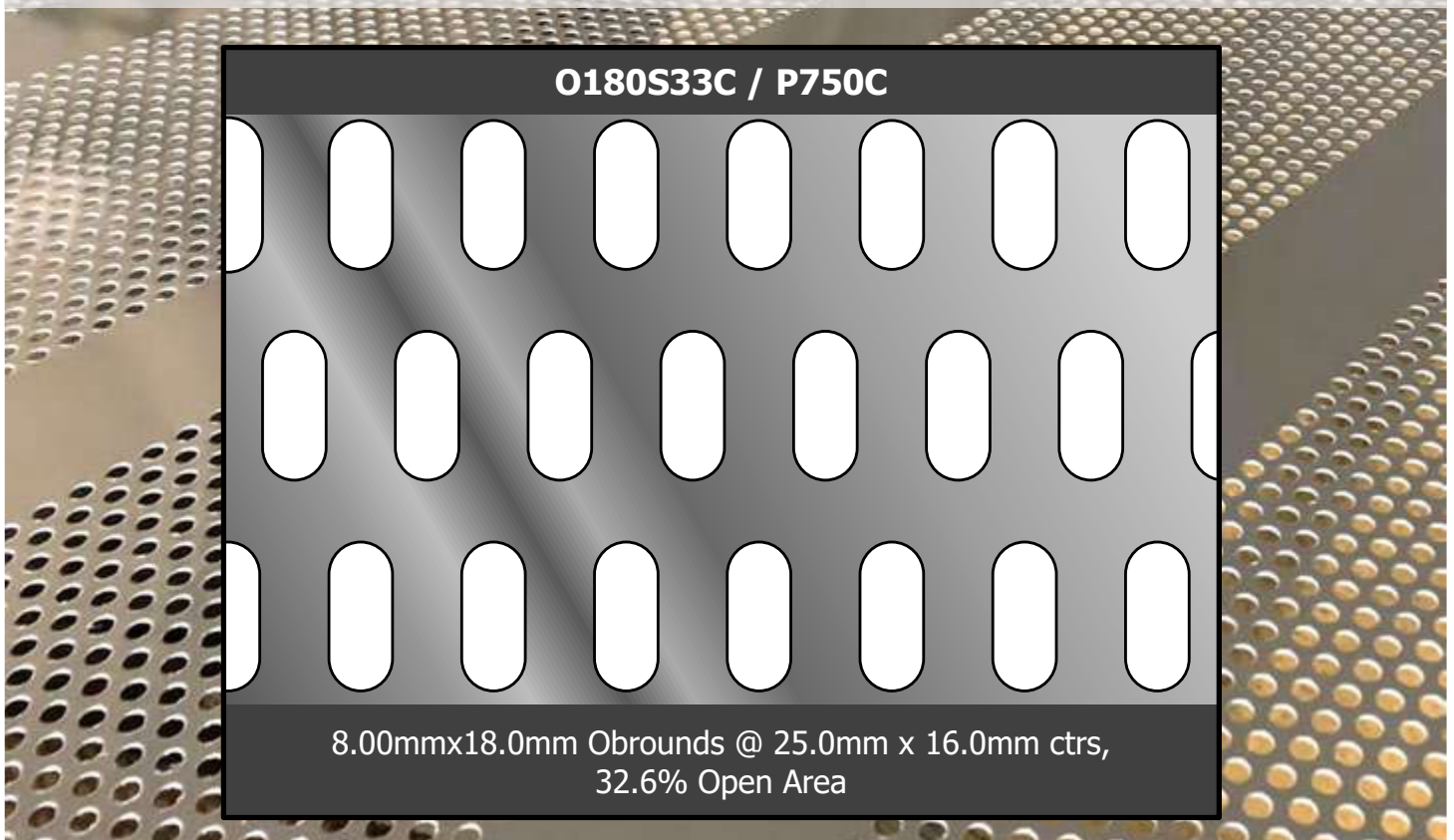

O180S33C / P750C

8.00mmx18.0mm Obrounds @ 25.0mm x 16.0mm ctrs,
32.6% Open Area



Rounds

R025B39 / P100 $\phi 2.5\text{mm}$ @ 5.00mm centres, 45° Stagger, 39.3% Open Area



Material	Sheet Thickness [mm]	
	min.	max.
Mild Steel	0.55	0.75
Galvanized Steel	0.55	0.75
Aluminium	0.5	0.70
Stainless Steel 304 or 316	0.5	0.70

R025B10 / P119 $\phi 2.5\text{mm}$ @ 10.00mm centres, 45° Stagger, 9.8% Open Area



Material	Sheet Thickness [mm]	
	min.	max.
Mild Steel	0.55	0.75
Galvanized Steel	0.55	0.75
Aluminium	0.50	0.70
Stainless Steel 304 or 316	0.50	0.70

R031A24 / P120 $\phi 3.1\text{mm}$ @ 6.00mm centres, 60° Stagger, 24.2% Open Area



Material	Sheet Thickness [mm]	
	min.	max.
Mild Steel	0.75	3.0
Galvanized Steel	0.75	3.0
Aluminium	0.75	3.0
Stainless Steel 304 or 316	1.0	1.5

R031A29 / P125 $\phi 3.1\text{mm}$ @ 5.53mm centres, 60° Stagger, 28.5% Open Area



Material	Sheet Thickness [mm]	
	min.	max.
Mild Steel	2.0	3.0
Galvanized Steel	2.0	3.0
Aluminium	2.0	3.0
Stainless Steel 304 or 316	1.6	1.6

Rounds

R032A37 / P129

ø3.2mm @ 5.01mm centres, 60° Stagger, 37% Open Area

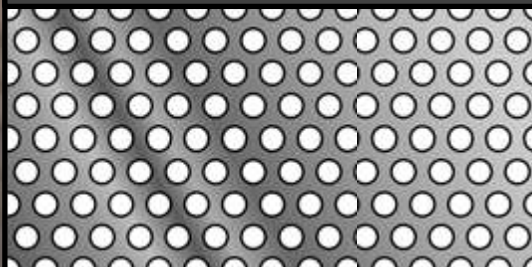
	Material	Sheet Thickness [mm]	
		min.	max.
	Mild Steel	0.75	0.75
	Galvanized Steel	0.75	0.75
	Aluminium	0.9	0.9
	Stainless Steel 304 or 316	NA	NA

R032A25 / P143

ø3.2mm @ 6.10mm centres, 60° Stagger, 25% Open Area

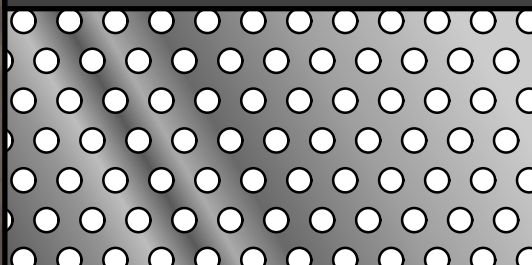
	Material	Sheet Thickness [mm]	
		min.	max.
	Mild Steel	0.75	1.2
	Galvanized Steel	0.75	1.2
	Aluminium	0.9	2.0
	Stainless Steel 304 or 316	0.75	0.75

R040C31

ø4.0mm @ 8.30mm centres, 50° Stagger, 30.6% Open Area

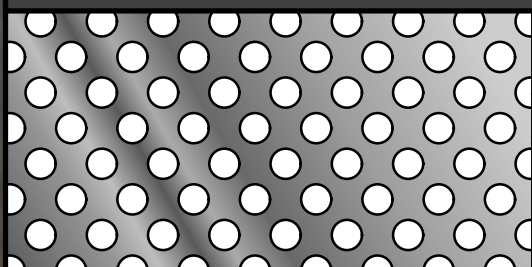
	Material	Sheet Thickness [mm]	
		min.	max.
	Mild Steel	0.75	2.0
	Galvanized Steel	0.75	2.0
	Aluminium	1.0	3.0
	Stainless Steel 304 or 316	0.75	1.2

R040B21 / P157

ø4.0mm @ 11.00mm centres, 45° Stagger, 20.8% Open Area

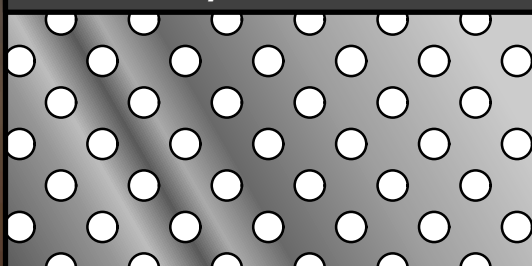
	Material	Sheet Thickness [mm]	
		min.	max.
	Mild Steel	0.75	1.2
	Galvanized Steel	0.75	1.2
	Aluminium	0.75	1.5
	Stainless Steel 304 or 316	NA	NA



Rounds



R040S26 / P158		$\varnothing 4.0\text{mm}$ @ 6.90mm centres, Rectangular, 26.4% Open Area		
	Material		Sheet Thickness [mm]	
			min.	max.
	Mild Steel		1.5	3.0
	Galvanized Steel		1.5	3.0
	Aluminium		1.5	3.0
Stainless Steel 304 or 316		1.5	1.5	

R040S07 / P159		$\varnothing 4.0\text{mm}$ @ 13.80mm centres, Rectangular, 26.6% Open Area		
	Material		Sheet Thickness [mm]	
			min.	max.
	Mild Steel		1.5	3.0
	Galvanized Steel		1.5	3.0
	Aluminium		1.5	3.0
Stainless Steel 304 or 316		1.5	1.5	

R048A50 / P186		$\varnothing 4.76\text{mm}$ @ 6.41mm centres, 60° Stagger, 50.0% Open Area		
	Material		Sheet Thickness [mm]	
			min.	max.
	Mild Steel		0.75	1.2
	Galvanized Steel		0.75	1.2
	Aluminium		0.75	2.0
Stainless Steel 304 or 316		1.2	1.2	



Rounds

R050A35 / P195 $\phi 5.00\text{mm}$ @ 8.00mm centres, 60° Stagger, 35.4% Open Area

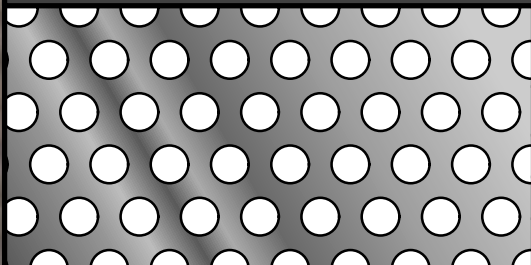
	Material		Sheet Thickness [mm]	
			min.	max.
	Mild Steel		0.75	1.6
	Galvanized Steel		0.75	1.6
	Aluminium		0.75	2.0
	Stainless Steel 304 or 316		1.0	1.3

R063A46 / P218 $\phi 6.30\text{mm}$ @ 8.89mm centres, 60° Stagger, 45.5% Open Area

	Material		Sheet Thickness [mm]	
			min.	max.
	Mild Steel		1.0	3.0
	Galvanized Steel		1.0	3.0
	Aluminium		1.0	3.0
	Stainless Steel 304 or 316		1.2	1.6

R063A40 / P220 $\phi 6.30\text{mm}$ @ 9.52mm centres, , 60° Stagger, – 39.7% Open Area

	Material		Sheet Thickness [mm]	
			min.	max.
	Mild Steel		0.9	3.0
	Galvanized Steel		0.9	3.0
	Aluminium		1.2	3.0
	Stainless Steel 304 or 316		1.2	1.6

R080A64 / P240 $\phi 8.0\text{mm}$ @ 9.55mm centres, 60° Stagger, 63.6% Open Area

	Material		Sheet Thickness [mm]	
			min.	max.
	Mild Steel		1.6	2.0
	Galvanized Steel		1.6	2.0
	Aluminium		2.0	3.0
	Stainless Steel 304 or 316		NA	NA



Rounds

R080A36 / P243		ø8.0mm @ 12.70mm centres, 60° Stagger, 36.0% Open Area	
	Material	Sheet Thickness [mm]	
		min.	max.
	Mild Steel	0.9	1.6
	Galvanized Steel	0.9	1.6
	Aluminium	0.9	2.0
Stainless Steel 304 or 316	1.2	1.6	

R095A40 / P266		ø9.52mm @ 14.3mm centres, 60° Stagger, 40.2% Open Area	
	Material	Sheet Thickness [mm]	
		min.	max.
	Mild Steel	1.2	2.5
	Galvanized Steel	1.2	2.5
	Aluminium	1.6	3.0
Stainless Steel 304 or 316	1.6	2.0	

R127S20		ø12.7mm @ 25.40mm centres, Rectangular, 19.6% Open Area	
	Material	Sheet Thickness [mm]	
		min.	max.
	Mild Steel	1.2	2.0
	Galvanized Steel	1.2	2.0
	Aluminium	1.2	3.0
Stainless Steel 304 or 316	1.6	1.6	

R127B39		ø12.7mm @ 25.40mm centres, 45° Stagger, 39.3% Open Area	
	Material	Sheet Thickness [mm]	
		min.	max.
	Mild Steel	1.2	2.0
	Galvanized Steel	1.2	2.0
	Aluminium	1.2	3.0
Stainless Steel 304 or 316	1.6	1.6	



Rounds

R127A49 / P291 $\phi 12.70\text{mm}$ @ 17.27mm centres, 60° Stagger, 49.0% Open Area

	Material	Sheet Thickness [mm]	
		min.	max.
	Mild Steel	0.9	2.0
	Galvanized Steel	0.9	2.0
	Aluminium	2.0	3.0
	Stainless Steel 304 or 316	1.6	1.6

R200A56 / P329 $\phi 19.00\text{mm}$ @ 25.40mm centres, 60° Stagger, 56.2% Open Area

	Material	Sheet Thickness [mm]	
		min.	max.
	Mild Steel	0.9	3.0
	Galvanized Steel	0.9	3.0
	Aluminium	1.2	4.0
	Stainless Steel 304 or 316	1.2	2.5

R318A51 / P349 $\phi 31.8\text{mm}$ @ 40mm centres, 60° Stagger, 51.00% Open Area

	Material	Sheet Thickness [mm]	
		min.	max.
	Mild Steel	0.55	3.0
	Galvanized Steel	0.55	3.0
	Aluminium	0.55	3.0
	Stainless Steel 304 or 316	0.75	2.0

Rounds – Peg Board

R048B06 / P185		ø4.76mm @ 25.4mm centres, 45° Stagger, – 5.5% Open Area		
	Material		Sheet Thickness [mm]	
			min.	max.
	Mild Steel		0.75	1.6
	Galvanized Steel		0.75	1.6
	Aluminium		0.75	2.0
Stainless Steel 304 or 316		NA	NA	

R048S03 / P188		ø4.76mm @ 25.40mm centres, Rectangular, 2.8% Open Area		
	Material		Sheet Thickness [mm]	
			min.	max.
	Mild Steel		0.75	1.6
	Galvanized Steel		0.75	1.6
	Aluminium		0.75	2.0
Stainless Steel 304 or 316		NA	NA	

R063B07 / P235		ø6.3mm @ 25.40mm centres, 45° Stagger, 6.8% Open Area		
	Material		Sheet Thickness [mm]	
			min.	max.
	Mild Steel		0.75	1.6
	Galvanized Steel		0.75	1.6
	Aluminium		0.9	2.0
Stainless Steel 304 or 316		NA	NA	

R063S05 / P238		ø6.3mm @ 25.40mm centres, Rectangular, 4.8% Open Area		
	Material		Sheet Thickness [mm]	
			min.	max.
	Mild Steel		0.75	1.6
	Galvanized Steel		0.75	1.6
	Aluminium		0.9	2.0
Stainless Steel 304 or 316		NA	NA	

Squares

Possible Square Perforation Orientations

Our most popular square perforation is of a rectangular orientation as shown in this catalogue.

If you would like to use another orientation, please contact us to discuss the options. Higher density patterns are more difficult to produce and have less options available.

Squares do not easily punch in stainless steel, although large squares on thin material are available with limited pattern choice.

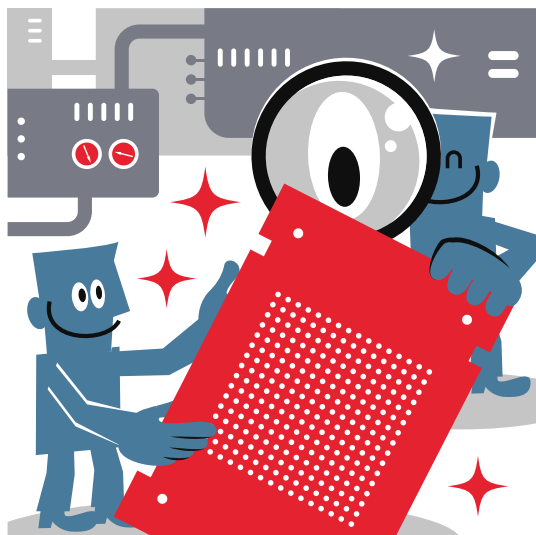

Low Density Rectangular Orientation

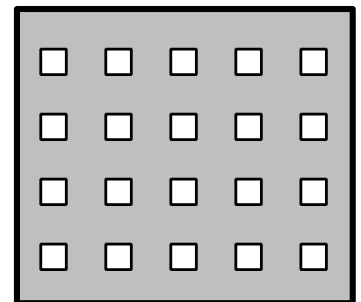

Checkered (Low Density Staggered Orientation)

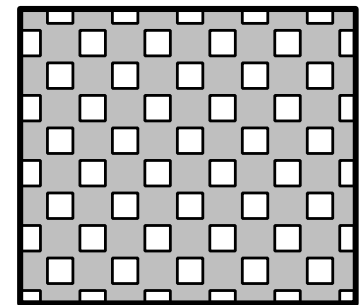

High Density Rectangular Orientation

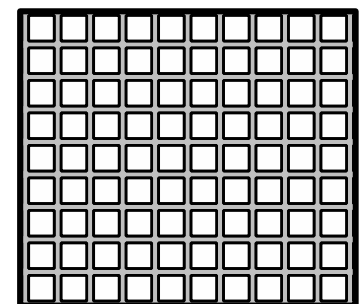

High Density Staggered Orientation

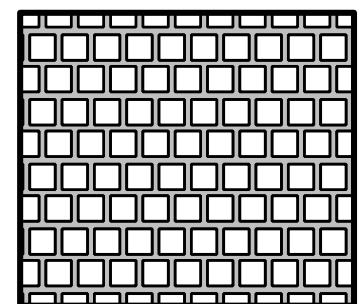



Squares

S032S16	3.2mm SQ, 7.9mm centres - 16.2% Open Area			
	Material		Sheet Thickness [mm]	
			min.	max.
	Mild Steel		1.0	1.6
	Galvanized Steel		1.0	1.6
	Aluminium		1.0	2.0
Stainless Steel 304 or 316		NA	NA	

S050S10 / P422	5.0mm SQ, 16.0mm centres – 9.8% Open Area			
	Material		Sheet Thickness [mm]	
			min.	max.
	Mild Steel		1.5	2.5
	Galvanized Steel		1.5	2.5
	Aluminium		1.5	3.0
Stainless Steel 304 or 316		NA	NA	

S062S19	6.2mm SQ, 14.2mm centres – 19.1% Open Area			
	Material		Sheet Thickness [mm]	
			min.	max.
	Mild Steel		0.75	0.75
	Galvanized Steel		0.75	0.75
	Aluminium		0.75	0.75
Stainless Steel 304 or 316		NA	NA	

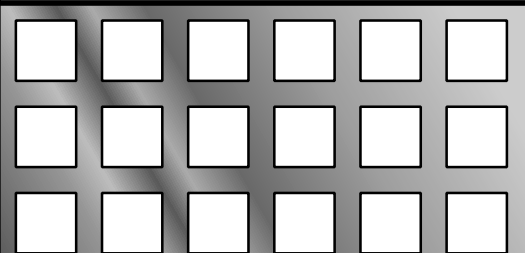
S080S49 / P448	8.0mm SQ, 11.43mm centres – 49.0% Open Area			
	Material		Sheet Thickness [mm]	
			min.	max.
	Mild Steel		0.75	2.0
	Galvanized Steel		0.75	2.0
	Aluminium		0.75	3.0
Stainless Steel 304 or 316		NA	NA	



Squares

Q080S16 8.0mm Radius Square, 20.0mm centres, Rectangular, 16% Open Area		Material		Sheet Thickness [mm]	
				min.	max.
		Mild Steel		0.75	1.6
		Galvanized Steel		0.75	1.6
		Aluminium		0.75	2.0
	Stainless Steel 304 or 316		NA	NA	

Q080G32 8.0mm Radius Square, 20.0mm centres, 45° Stagger, 32% Open Area		Material		Sheet Thickness [mm]	
				min.	max.
		Mild Steel		0.75	1.6
		Galvanized Steel		0.75	1.6
		Aluminium		0.75	2.0
	Stainless Steel 304 or 316		NA	NA	

S091S13 9.1mm SQ, 25mm centres, 13% Open Area		Material		Sheet Thickness [mm]	
				min.	max.
		Mild Steel		1.2	2.5
		Galvanized Steel		1.2	2.5
		Aluminium		1.2	3.0
	Stainless Steel 304 or 316		NA	NA	

S100S44 / P450 10.0mm SQ, 15mm centres, 44.4% Open Area		Material		Sheet Thickness [mm]	
				min.	max.
		Mild Steel		1.0	2.0
		Galvanized Steel		1.0	2.0
		Aluminium		1.0	3.0
	Stainless Steel 304 or 316		NA	NA	

Squares

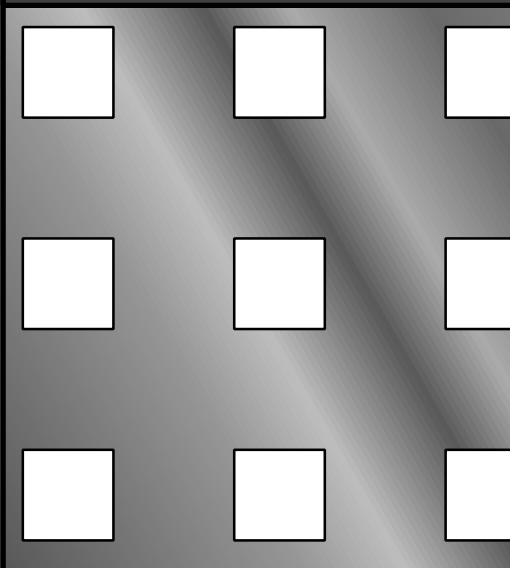

S110S48 / P458		11.0mm SQ, 15.9mm centres, 48.0% Open Area		
	Material		Sheet Thickness [mm]	
			min.	max.
	Mild Steel		0.75	1.2
	Galvanized Steel		0.75	1.2
	Aluminium		0.75	2.0
Stainless Steel 304 or 316		NA	NA	

S120S18		12.0mm SQ, 28.0mm centres, 18.4% Open Area		
	Material		Sheet Thickness [mm]	
			min.	max.
	Mild Steel		1.2	2.0
	Galvanized Steel		1.2	2.0
	Aluminium		1.2	3.0
Stainless Steel 304 or 316		NA	NA	

Squares



S180S20		18.0mm SQ, 40.0mm centres, 20.3% Open Area		
		Material	Sheet Thickness [mm]	
			min.	max.
		Mild Steel	0.75	1.5
		Galvanized Steel	0.75	1.5
		Aluminium	0.75	2.0
		Stainless Steel 304 or 316	NA	NA

S300S56 / P470		30.0mm SQ, 40.0mm centres, 56.3% Open Area		
		Material	Sheet Thickness [mm]	
			min.	max.
		Mild Steel	0.75	3.0
		Galvanized Steel	0.75	3.0
		Aluminium	0.75	3.0
		Stainless Steel 304 or 316	1.0	1.6

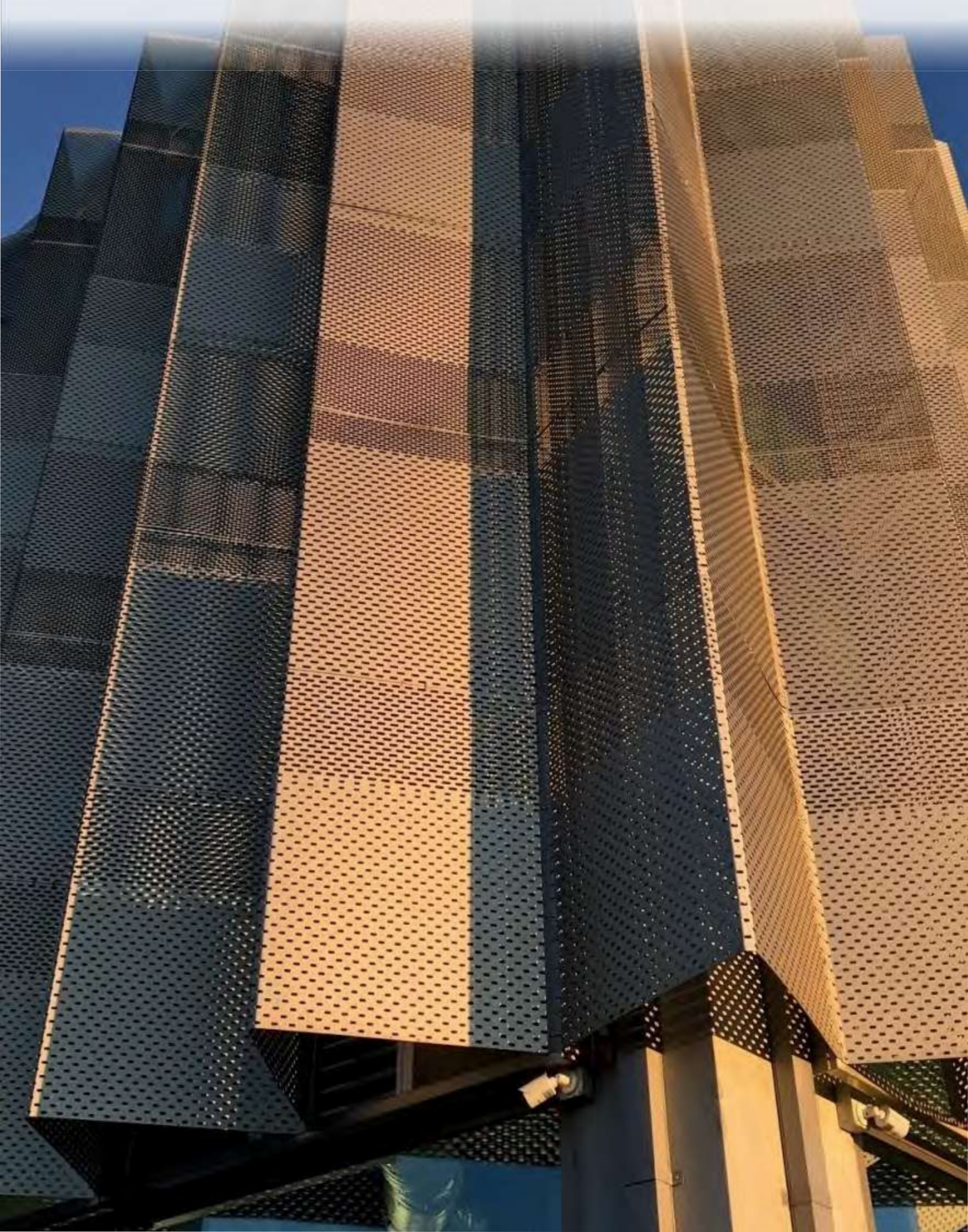



Rectangular Slots

The rectangular perforations (with square corners) displayed on this page also have a radius rectangle alternative (with rounded corners) that can be run with 1.2mm stainless steel, as well as mild/galvanized steel and aluminium.

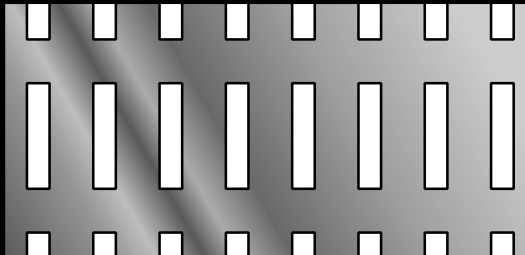
C140S24	14x3mm Rectangles, 8.80 x 19.8mm centres, 24.1% Open Area	Material	Sheet Thickness [mm]	
			min.	max.
		Mild Steel	1.0	1.6
		Galvanized Steel	1.0	1.6
		Aluminium	1.0	2.0
		Stainless Steel 304 or 316	NA	NA

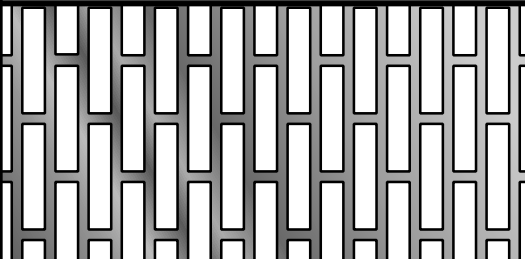
C140G62	14x3mm Rectangles, 15.4x4.4mm centres, 62% Open Area	Material	Sheet Thickness [mm]	
			min.	max.
		Mild Steel	1.0	1.6
		Galvanized Steel	1.0	1.6
		Aluminium	1.0	2.0
		Stainless Steel 304 or 316	NA	NA

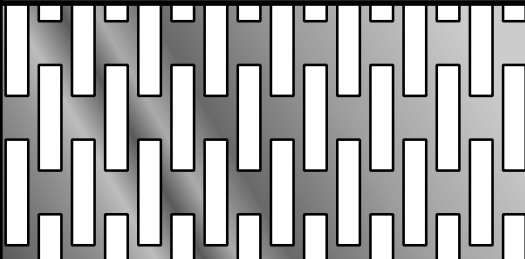
C140G48	14x3mm Rectangles, 19.8x4.4mm centres, 48.2% Open Area	Material	Sheet Thickness [mm]	
			min.	max.
		Mild Steel	1.0	1.6
		Galvanized Steel	1.0	1.6
		Aluminium	1.0	2.0
		Stainless Steel 304 or 316	NA	NA

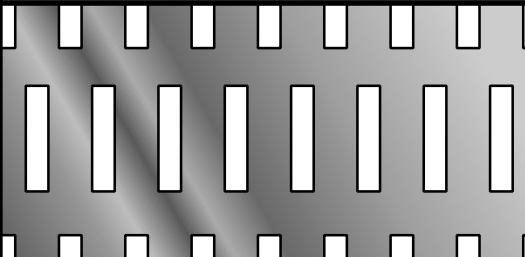
C140E23	14x3mm Rectangles, 19.8x8.8mm centres, 23% Open Area	Material	Sheet Thickness [mm]	
			min.	max.
		Mild Steel	1.0	1.6
		Galvanized Steel	1.0	1.6
		Aluminium	1.0	2.0
		Stainless Steel 304 or 316	NA	NA



Rectangular Slots

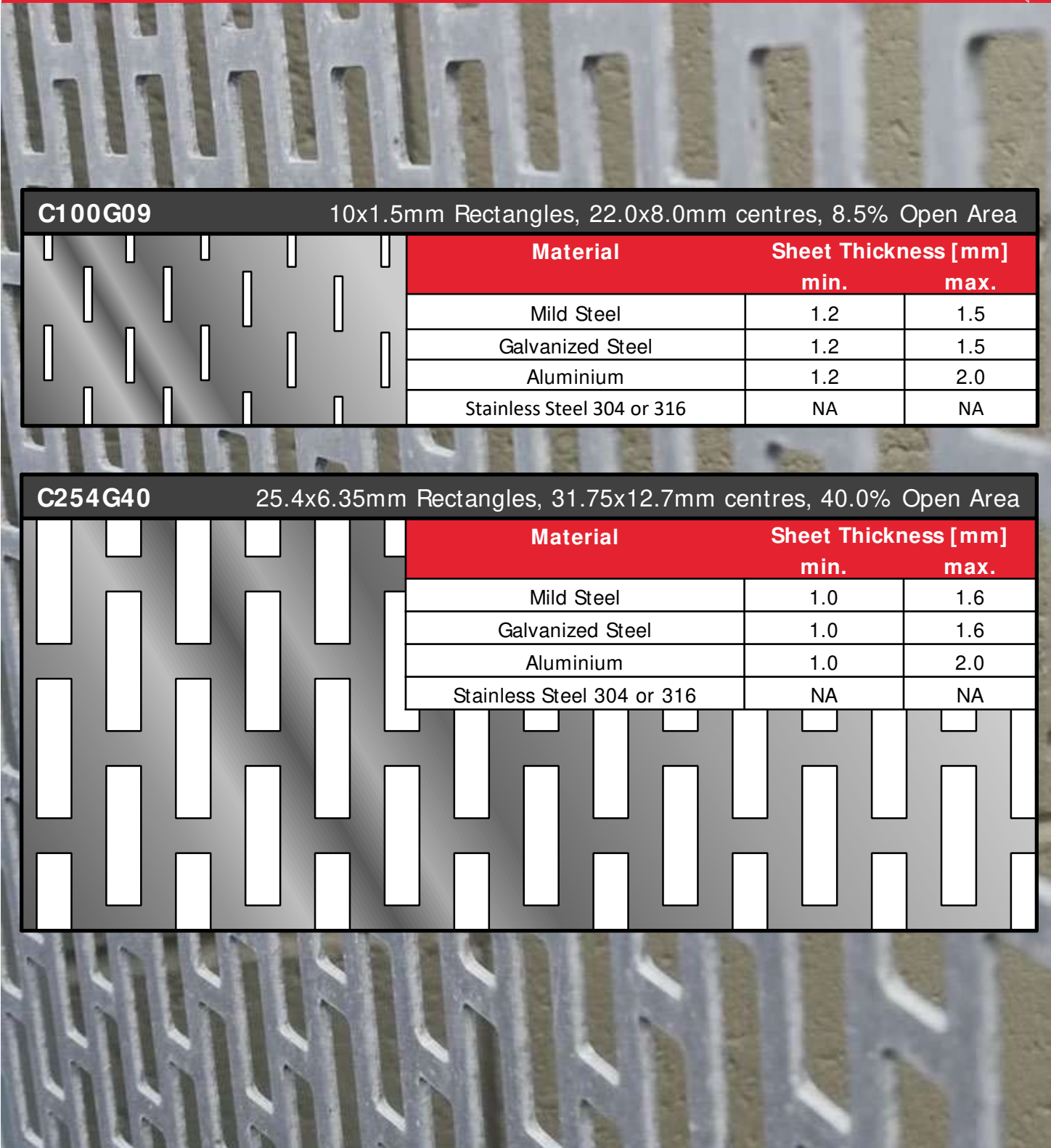

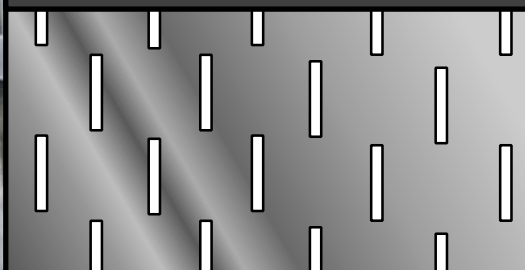
C100G09	10x1.5mm Rectangles, 22.0x8.0mm centres, 8.5% Open Area		
	Material	Sheet Thickness [mm]	
		min.	max.
	Mild Steel	1.2	1.5
	Galvanized Steel	1.2	1.5
	Aluminium	1.2	2.0
	Stainless Steel 304 or 316	NA	NA

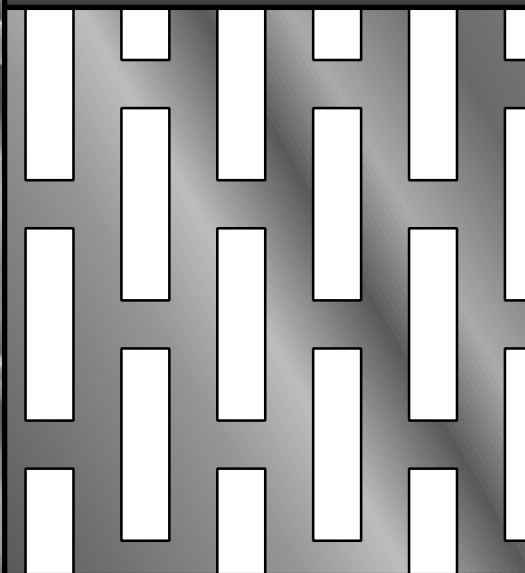
C254G40	25.4x6.35mm Rectangles, 31.75x12.7mm centres, 40.0% Open Area		
	Material	Sheet Thickness [mm]	
		min.	max.
	Mild Steel	1.0	1.6
	Galvanized Steel	1.0	1.6
	Aluminium	1.0	2.0
	Stainless Steel 304 or 316	NA	NA



Rectangular Slots

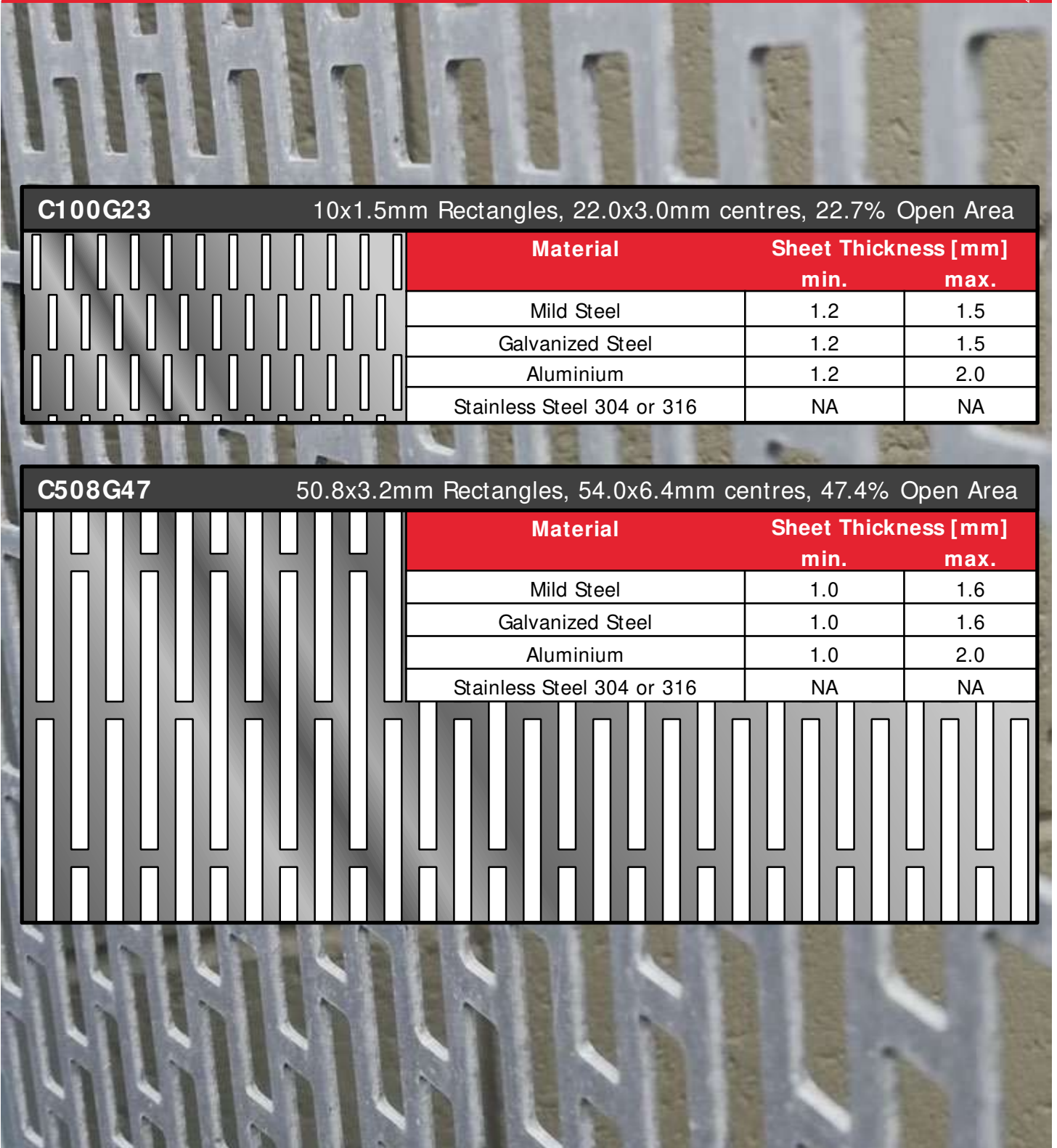

C100G23

10x1.5mm Rectangles, 22.0x3.0mm centres, 22.7% Open Area

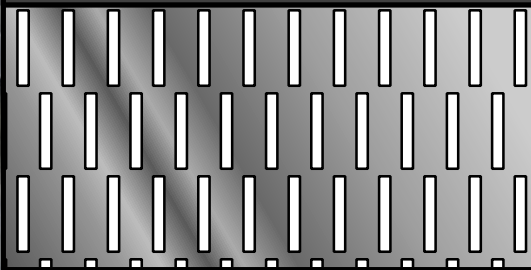
	Material	Sheet Thickness [mm]	
		min.	max.
	Mild Steel	1.2	1.5
	Galvanized Steel	1.2	1.5
	Aluminium	1.2	2.0
	Stainless Steel 304 or 316	NA	NA

C508G47

50.8x3.2mm Rectangles, 54.0x6.4mm centres, 47.4% Open Area

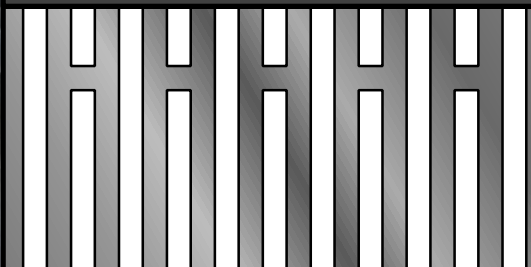
	Material	Sheet Thickness [mm]	
		min.	max.
	Mild Steel	1.0	1.6
	Galvanized Steel	1.0	1.6
	Aluminium	1.0	2.0
	Stainless Steel 304 or 316	NA	NA



Rectangular Slots

C250S28 / P488

25.0x2.5mm holes, 30.0x7.5mm centres, 27.8% Open Area
For Mechanical Use Only

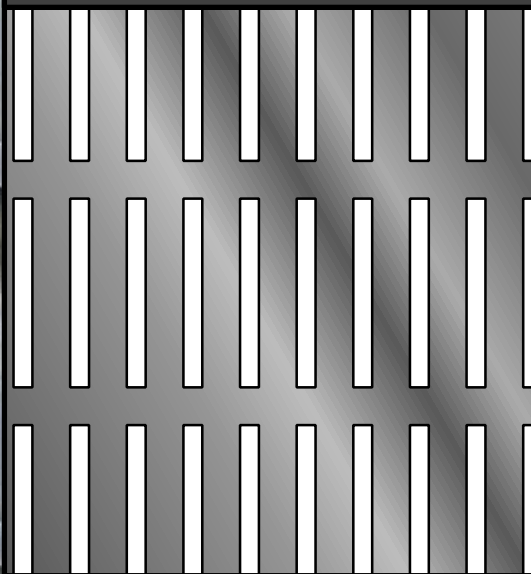
	Material	Sheet Thickness [mm]	
		min.	max.
	Mild Steel	1.6	1.6
	Galvanized Steel	1.6	1.6
	Aluminium	1.2	2.0
	Stainless Steel 304 or 316	1.6	1.6

C264G46 / P922

25.95x8.0mm Rectangle Radius, 31.0x15.5mm centres, 46.1% Open Area

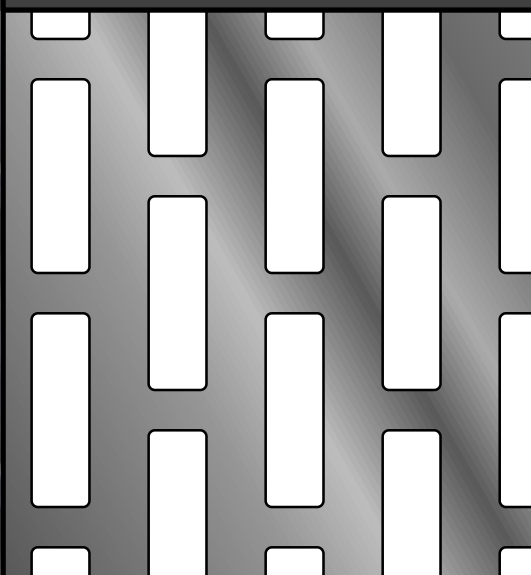
	Material	Sheet Thickness [mm]	
		min.	max.
	Mild Steel	1.2	2.0
	Galvanized Steel	1.2	2.0
	Aluminium	1.6	3.0
	Stainless Steel 304 or 316	1.2	1.6



Obround Slots

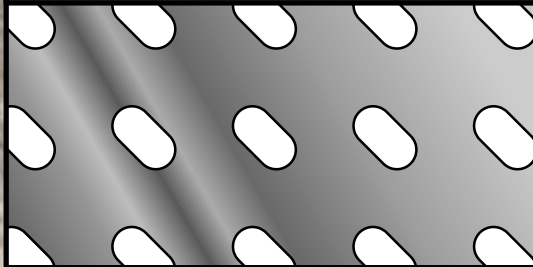

O100X19		10x5.5mm obrounds, 11.3x7.5mm centres, 19.0% Open Area		
	Material	Sheet Thickness [mm]		
		min.	max.	
	Mild Steel	0.55	2.0	
	Galvanized Steel	0.55	2.0	
	Aluminium	0.75	3.0	
Stainless Steel 304 or 316	1.2	1.2		

O100X57		10x5.5mm obrounds, 11.3x7.5mm centres, 57.2% Open Area		
	Material	Sheet Thickness [mm]		
		min.	max.	
	Mild Steel	0.55	2.0	
	Galvanized Steel	0.55	2.0	
	Aluminium	0.75	3.0	
Stainless Steel 304 or 316	1.2	1.2		

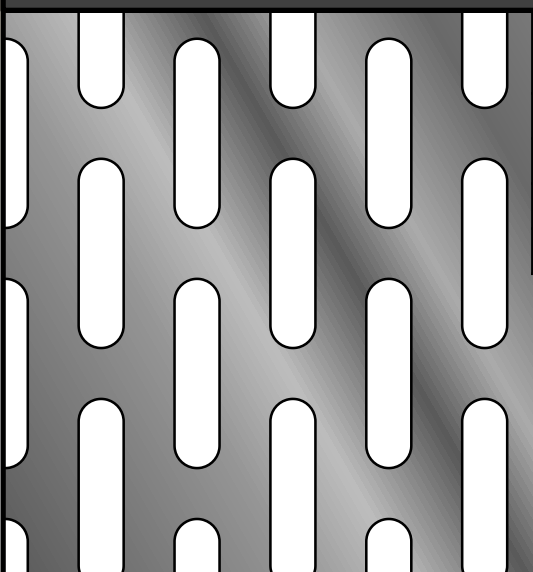
O254G38		25.4x6.3mm obrounds, 31.8x12.7mm centres, 37.5% Open Area		
	Material	Sheet Thickness [mm]		
		min.	max.	
	Mild Steel	0.75	1.6	
	Galvanized Steel	0.75	1.6	
	Aluminium	0.75	2.0	
Stainless Steel 304 or 316	NA	NA		

Obround Slots



O250G40 / P588

25x5mm holes, 30x10 centres, 39.9% Open Area

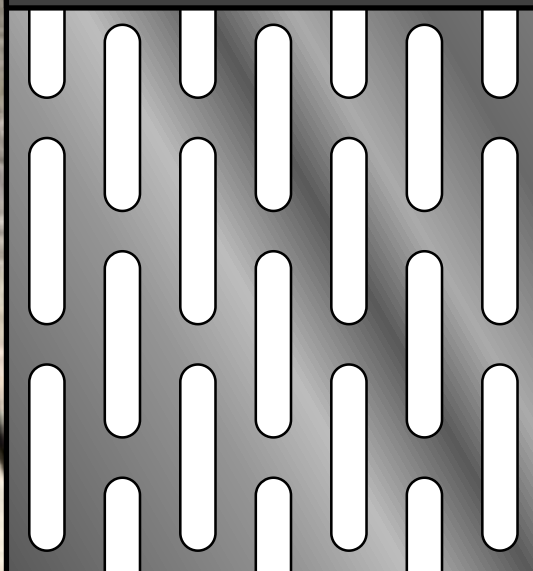
	Material	Sheet Thickness [mm]	
		min.	max.
	Mild Steel	1.0	1.6
	Galvanized Steel	1.0	1.6
	Aluminium	1.0	2.0
	Stainless Steel 304 or 316	Mechanical Use Only	Mechanical Use Only

O254S11 / P720

25.4x2.4mm, 35.4x14.8 mm centres, 11.4% Open Area

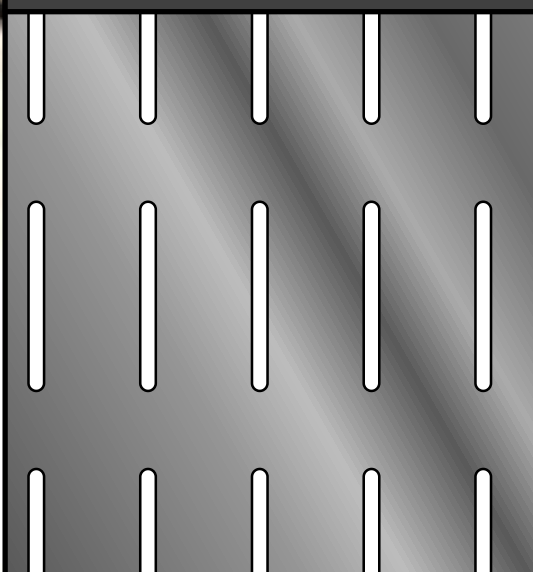
	Material	Sheet Thickness [mm]	
		min.	max.
	Mild Steel	1.0	2.0
	Galvanized Steel	1.0	2.0
	Aluminium	1.0	3.0
	Stainless Steel 304 or 316	1.2	1.2



Obround Slots

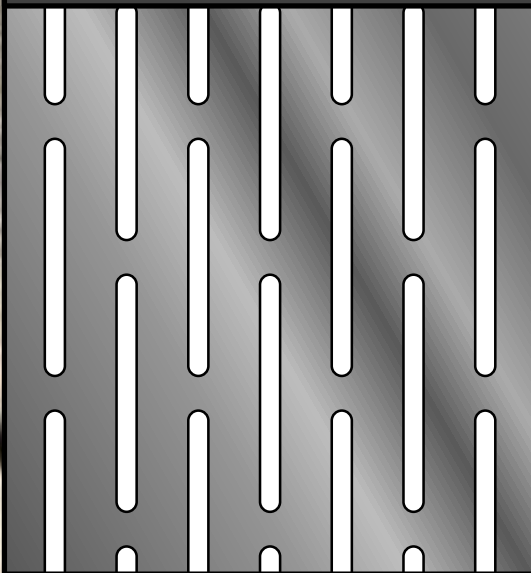

O318G27 31.75x3mm holes, 36x9.5mm centres, Side Staggered 27.3% Open Area			
	Material	Sheet Thickness [mm]	
		min.	max.
	Mild Steel	1.0	2.0
	Galvanized Steel	1.0	2.0
	Aluminium	1.0	3.0
	Stainless Steel 304 or 316	1.2	1.2

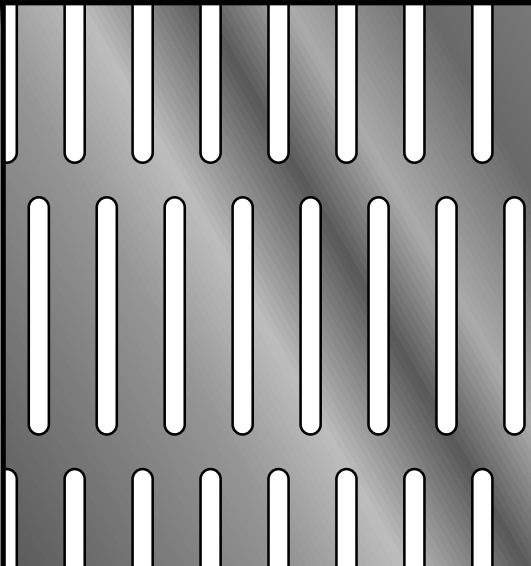
O318E27 31.75x3mm holes, 36x9.5mm centres, End Staggered 27.3% Open Area			
	Material	Sheet Thickness [mm]	
		min.	max.
	Mild Steel	1.0	2.0
	Galvanized Steel	1.0	2.0
	Aluminium	1.0	3.0
	Stainless Steel 304 or 316	1.2	1.2



Obround Slots

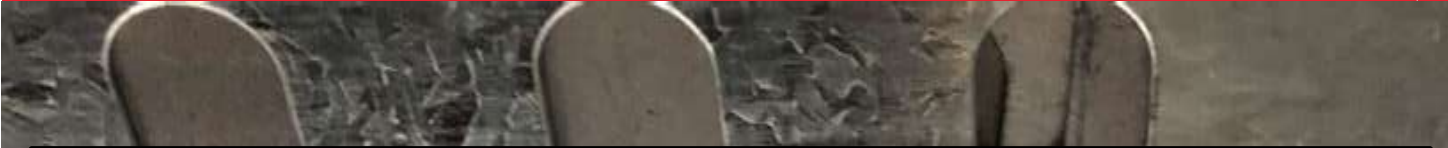

O318G45 31.75x3.18mm Holes, 34.9x6.4mm centres, 44.5% Open Area

Material	Sheet Thickness [mm]	
	min.	max.
Mild Steel	0.75	1.6
Galvanized Steel	0.75	1.6
Aluminium	1.0	2.5
Stainless Steel 304 or 316	NA	NA

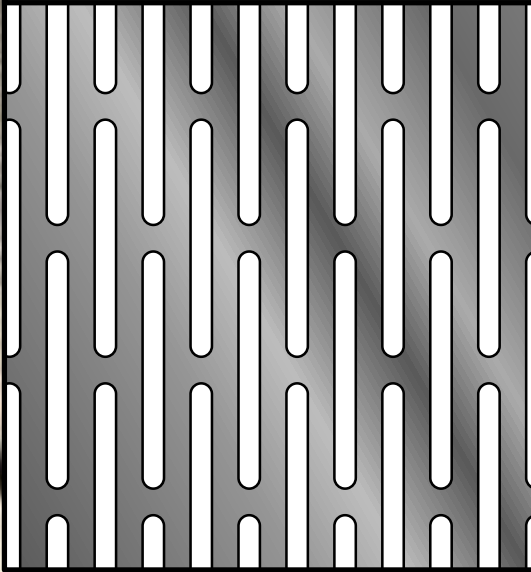

O548G56 54.76x7.92mm Holes, 57.80x12.90 centres, Side Staggered, 56.4% Open Area

Material	Sheet Thickness [mm]	
	min.	max.
Mild Steel	0.75	1.6
Galvanized Steel	0.75	1.6
Aluminium	1.0	2.5
Stainless Steel 304 or 316	NA	NA

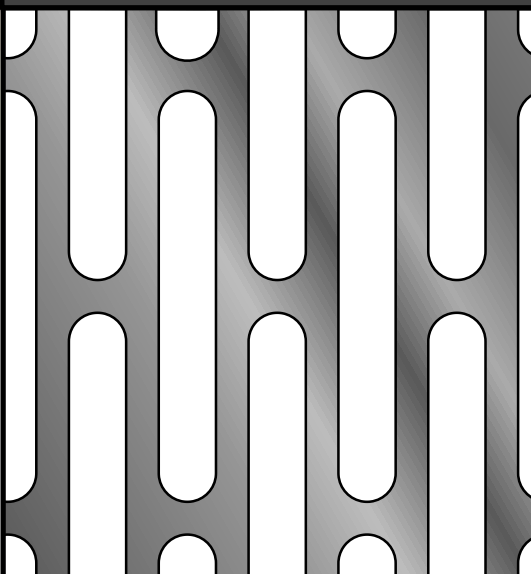



Hexagonal



H042C65	4.2mm Hexagons, Honeycomb, 65.2% Open Area		
	Material	Sheet Thickness [mm]	
		min.	max.
	Mild Steel	0.75	1.2
	Galvanized Steel	0.75	1.2
	Aluminium	0.75	2.0
	Stainless Steel 304 or 316	NA	NA

H064C75	6.35mm Hexagons, Honeycomb, 75.2% Open Area		
	Material	Sheet Thickness [mm]	
		min.	max.
	Mild Steel	0.75	1.5
	Galvanized Steel	0.75	1.5
	Aluminium	1.0	2.5
	Stainless Steel 304 or 316	NA	NA

H079C74	7.85mm Hexagons, Honeycomb, 73.6% Open Area		
	Material	Sheet Thickness [mm]	
		min.	max.
	Mild Steel	0.75	1.5
	Galvanized Steel	0.75	1.5
	Aluminium	1.0	2.5
	Stainless Steel 304 or 316	NA	NA





Hexagonal

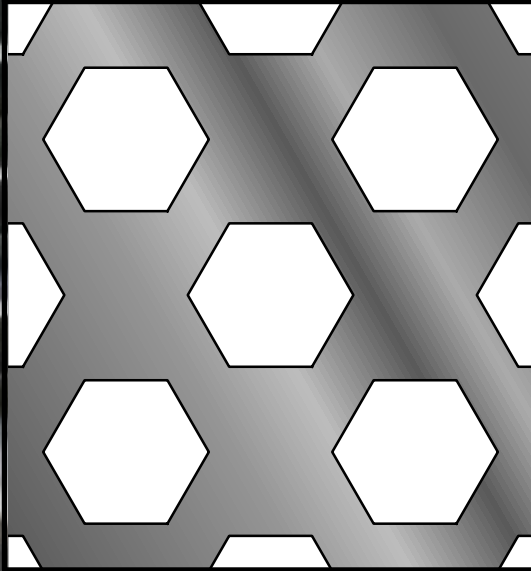

H190C41	19.0mm Hexagons, Staggered, 40.7% Open Area		
	Material	Sheet Thickness [mm]	
		min.	max.
	Mild Steel	0.75	1.5
	Galvanized Steel	0.75	1.5
	Aluminium	1.0	2.5
	Stainless Steel 304 or 316	NA	NA

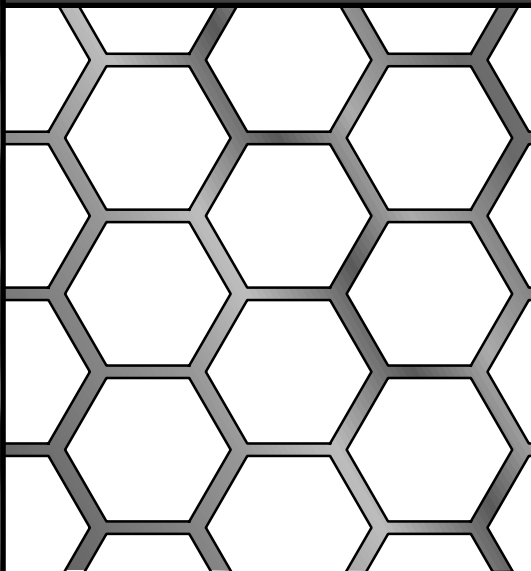
H190C85	19.0mm Hexagons, Honeycomb Pattern, 84.7% Open Area		
	Material	Sheet Thickness [mm]	
		min.	max.
	Mild Steel	0.75	1.5
	Galvanized Steel	0.75	1.5
	Aluminium	1.0	2.5
	Stainless Steel 304 or 316	NA	NA



Dimples

OSH10 Safety Tread Plate
With hole in each dimple

19.0-35.0mm Dimples, 43mm centres
12mm hole @ 43mm centres
21.5 % Open Area

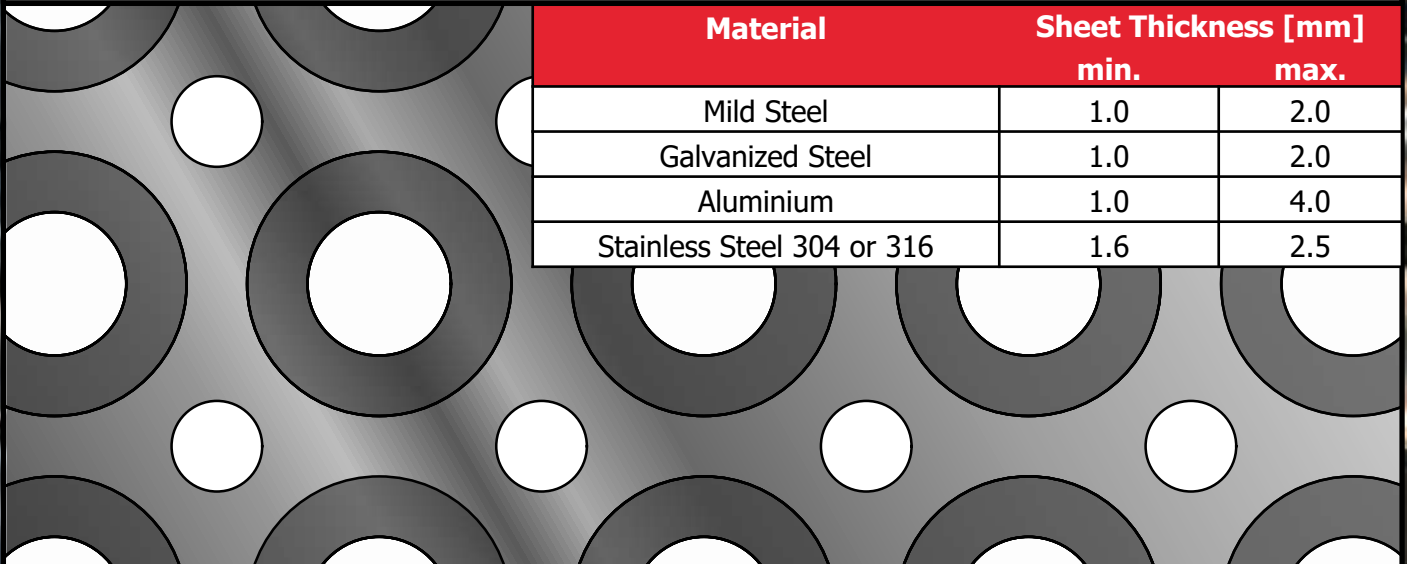

Material	Sheet Thickness [mm]	
	min.	max.
Mild Steel	1.0	2.0
Galvanized Steel	1.0	2.0
Aluminium	1.0	4.0
Stainless Steel 304 or 316	1.6	2.5

OSH6 Safety Tread Plate
With hole in each dimple

7.0-12.0mm Dimples, 50.8mm centres
6.35mm holes @ 50.8mm centres
2.5% Open Area

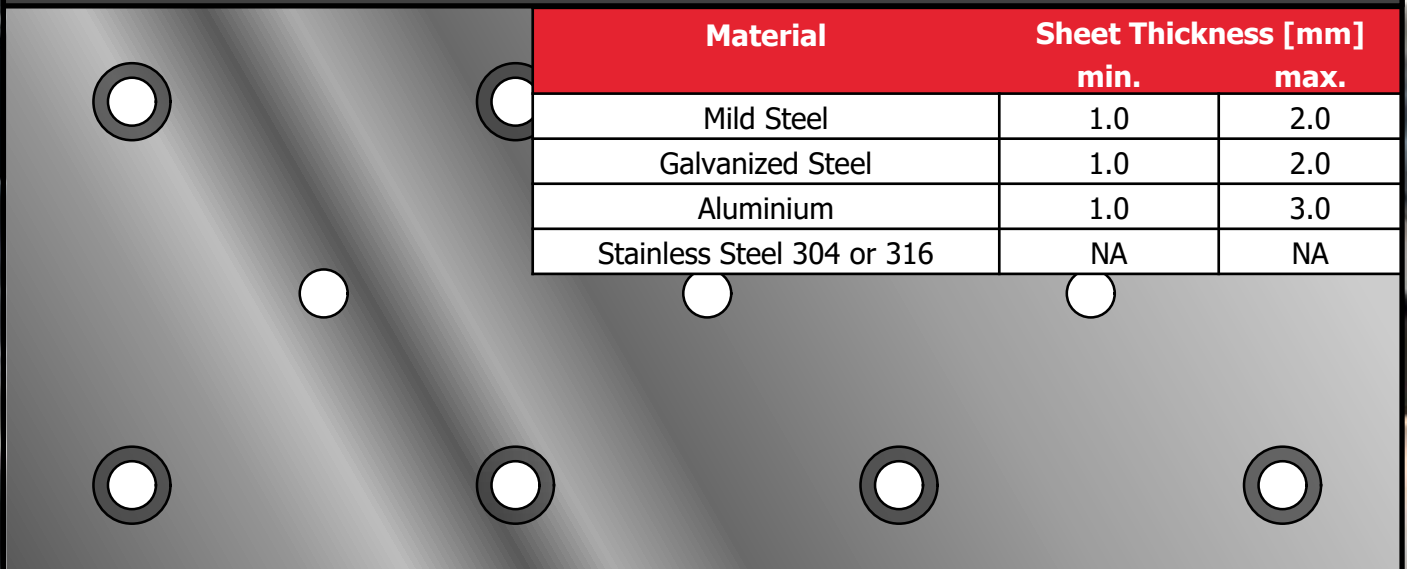

Material	Sheet Thickness [mm]	
	min.	max.
Mild Steel	1.0	2.0
Galvanized Steel	1.0	2.0
Aluminium	1.0	3.0
Stainless Steel 304 or 316	NA	NA



Dimples

We also have a selection of obround, square and rectangle dimple tools to choose from for any special forming requirements.

P622

Option to punch holes in dimples

7.0-23.0mm dimples, 26mm centres, rectangular, 0% Open Area

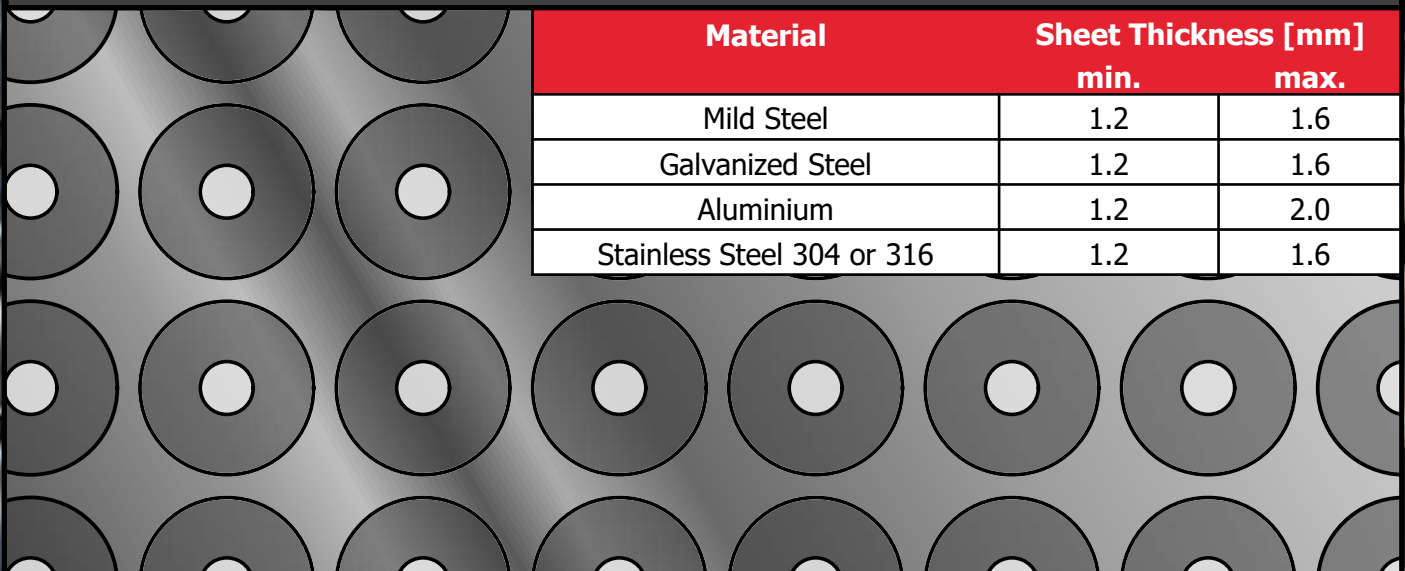

Material	Sheet Thickness [mm]	
	min.	max.
Mild Steel	1.2	1.6
Galvanized Steel	1.2	1.6
Aluminium	1.2	2.0
Stainless Steel 304 or 316	1.2	1.6

P644

Option to punch holes in dimples

18.0-36.0mm dimples, 49.0mm centres, staggered, 0% open area

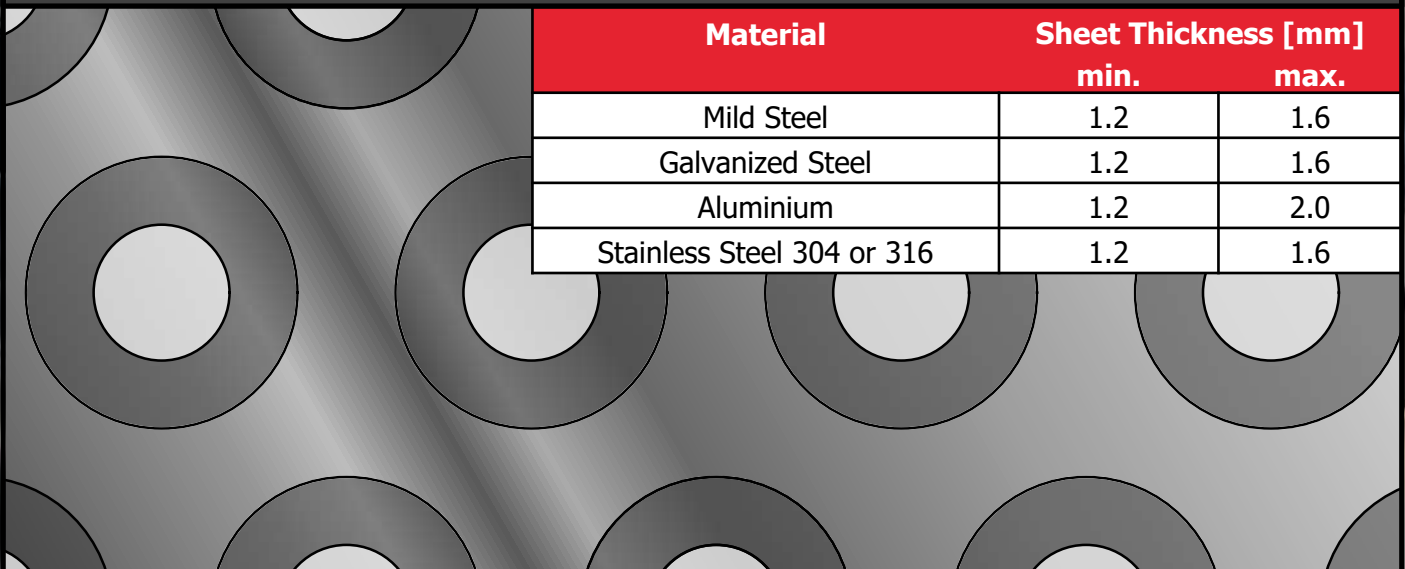

Material	Sheet Thickness [mm]	
	min.	max.
Mild Steel	1.2	1.6
Galvanized Steel	1.2	1.6
Aluminium	1.2	2.0
Stainless Steel 304 or 316	1.2	1.6





Decorative



Karaka / X375G46

37.5mm cross tool, 46.4% Open Area

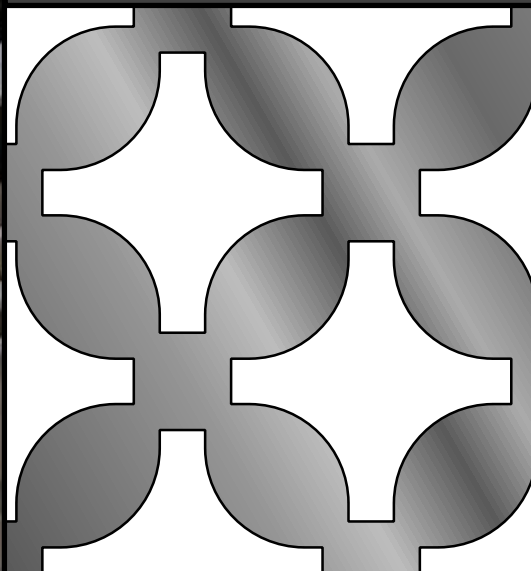
	Material	Sheet Thickness [mm]	
		min.	max.
	Mild Steel	0.75	2.0
	Galvanized Steel	0.75	2.0
	Aluminium	1.0	3.0
	Stainless Steel 304 or 316	NA	NA

Tarata / X343G41

34.3mm rounded cross tool, 41.3% Open Area

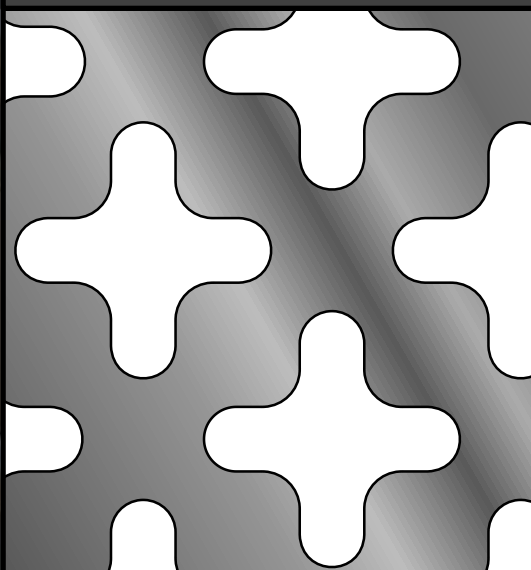
	Material	Sheet Thickness [mm]	
		min.	max.
	Mild Steel	0.75	2.0
	Galvanized Steel	0.75	2.0
	Aluminium	1.0	3.0
	Stainless Steel 304 or 316	1.2	1.2

Decorative

Harakeke / T175X67

17.5mm triangles arranged in a woven pattern, 66.5% Open Area

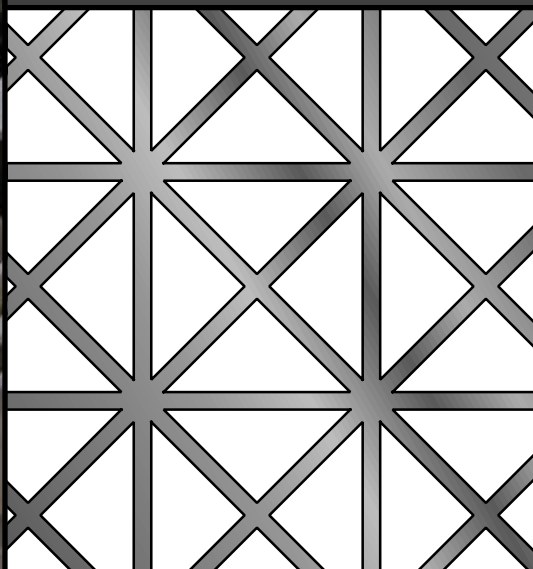
	Material	Sheet Thickness [mm]	
		min.	max.
	Mild Steel	0.55	2.0
	Galvanized Steel	0.55	2.0
	Aluminium	0.75	3.0
	Stainless Steel 304 or 316	NA	NA

Punga Tahi / X152S40

26mm square, special cluster, Rectangular, 39.7% Open Area

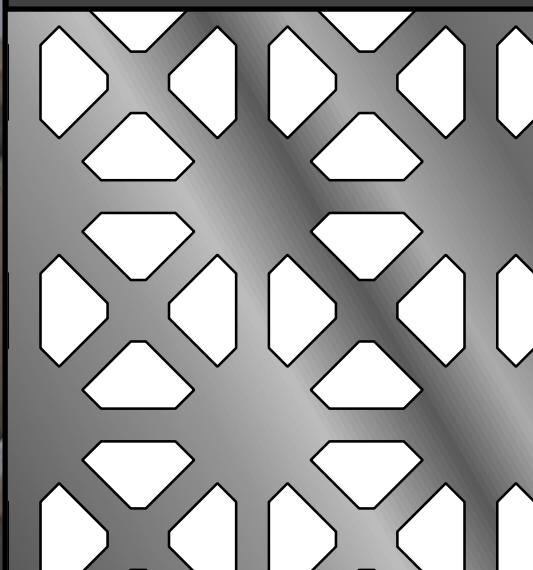
	Material	Sheet Thickness [mm]	
		min.	max.
	Mild Steel	1.2	1.6
	Galvanized Steel	1.2	1.6
	Aluminium	1.2	2.0
	Stainless Steel 304 or 316	1.2	1.2

Decorative

Punga Rua / X152S52

26mm SQ Special Cluster with 12mm Round tool, Rectangular, 52.1% Open Area

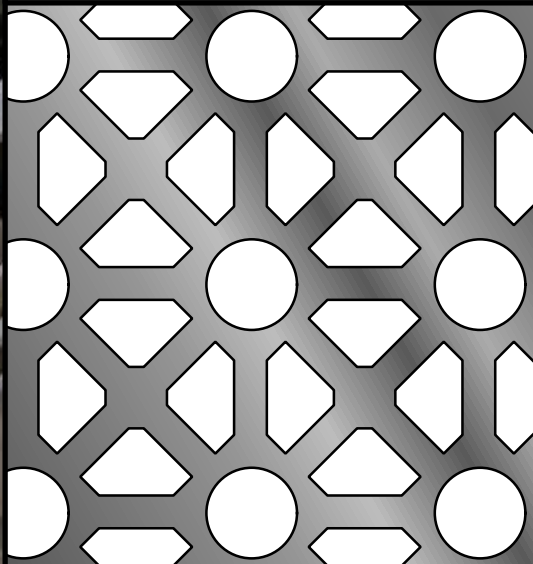
	Material	Sheet Thickness [mm]	
		min.	max.
	Mild Steel	1.2	1.6
	Galvanized Steel	1.2	1.6
	Aluminium	1.2	2.0
	Stainless Steel 304 or 316	1.2	1.2

Punga Toru / X152S56

26mm SQ Special Cluster with 12mm Square tool, Rectangular, 55.5% Open Area

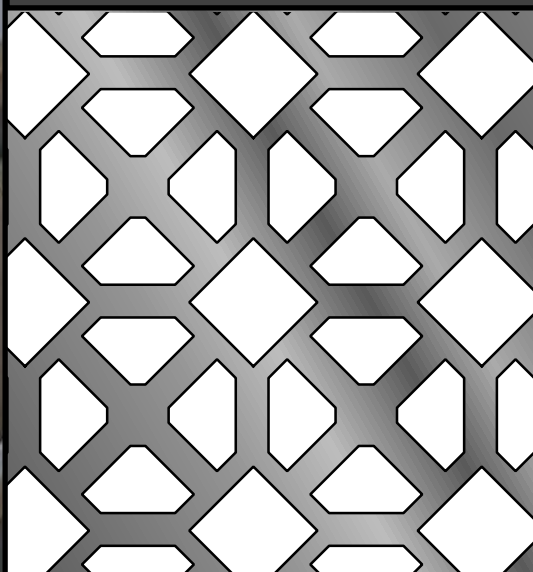
	Material	Sheet Thickness [mm]	
		min.	max.
	Mild Steel	1.2	1.6
	Galvanized Steel	1.2	1.6
	Aluminium	1.2	2.0
	Stainless Steel 304 or 316	1.2	1.2





Decorative

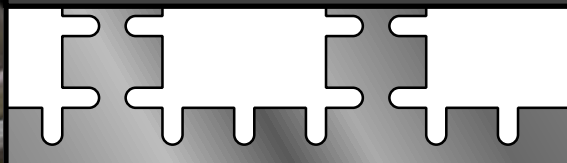
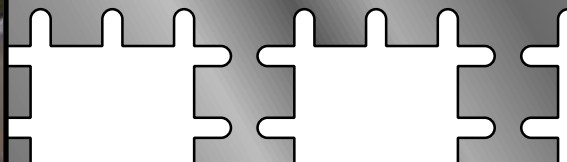
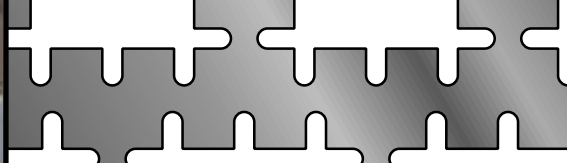

Tutu / X318G54

31.6mm SQ, Staggered, 54.0% Open Area

	Material	Sheet Thickness [mm]	
		min.	max.
	Mild Steel	0.75	2.0
	Galvanized Steel	0.75	2.0
	Aluminium	1.0	3.0
	Stainless Steel 304 or 316	NA	NA





Decorative

These perforations are displayed at a scale of 0.5

Pohutakawa / X311X38

31.1 x 22.7mm composite shape,
38.2% Open Area

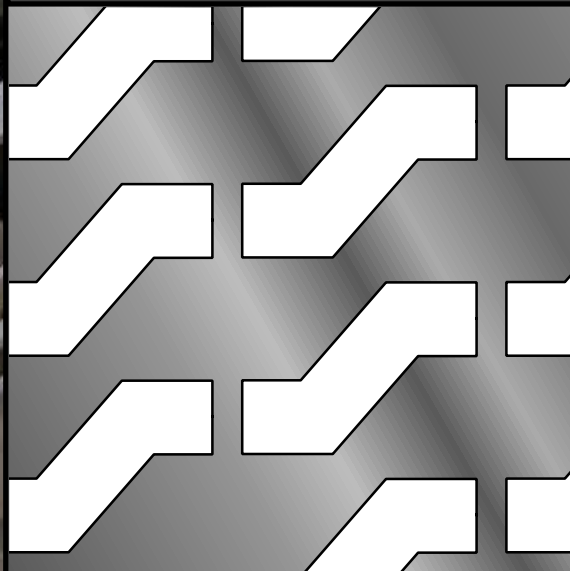
	Material	Sheet Thickness [mm]	
		min.	max.
	Mild Steel	1.6	2.5
	Galvanized Steel	1.6	2.5
	Aluminium	1.6	3.0
	Stainless Steel 304 or 316	NA	NA

Karetu / T442X58

44mm height isosceles triangles, staggered and
alternating, 58.0% Open Area

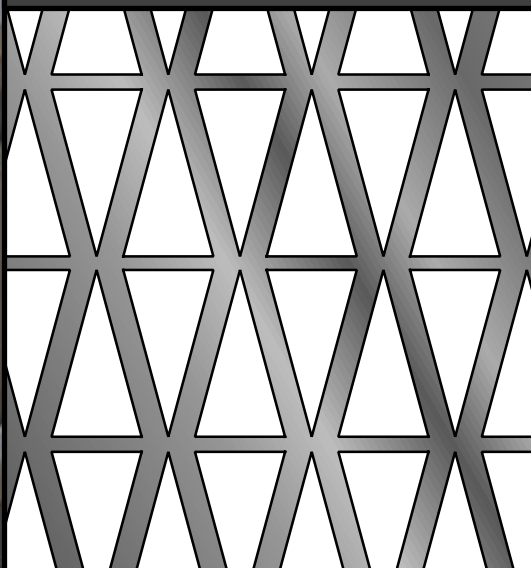
	Material	Sheet Thickness [mm]	
		min.	max.
	Mild Steel	0.75	1.6
	Galvanized Steel	0.75	1.6
	Aluminium	1.0	2.0
	Stainless Steel 304 or 316	NA	NA



Decorative

These perforations are displayed at a scale of 0.5
They are suited for large scale architectural use

Totara / T536X40

46.5mm side triangles, staggered and alternating, 40.0% Open Area

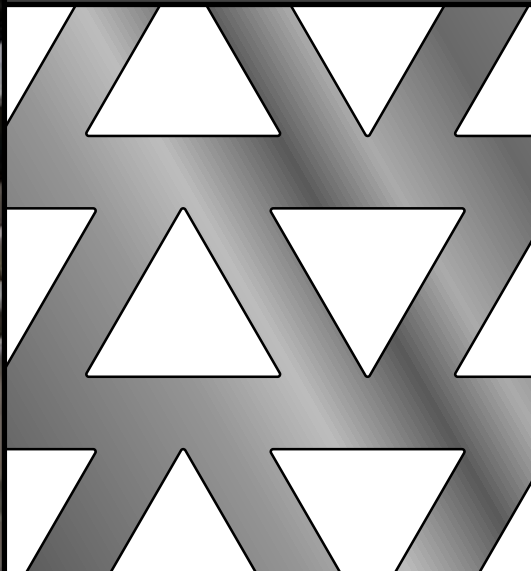
	Material	Sheet Thickness [mm]	
		min.	max.
	Mild Steel	1.0	2.0
	Galvanized Steel	1.0	2.0
	Aluminium	1.0	3.0
	Stainless Steel 304 or 316	NA	NA

Kauri / X600G38

26mm irregular hexagons, staggered, 38.0% Open Area

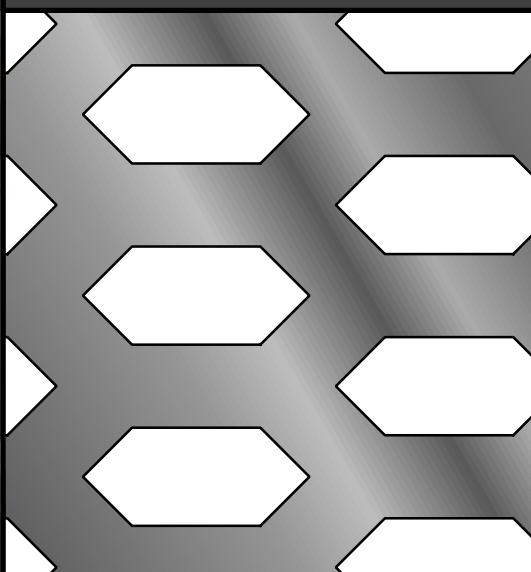
	Material	Sheet Thickness [mm]	
		min.	max.
	Mild Steel	1.0	2.0
	Galvanized Steel	1.0	2.0
	Aluminium	1.0	3.0
	Stainless Steel 304 or 316	NA	NA



Decorative - Diamonds



ToeToe Tahī / V091S09

9.1mm sq diamonds, 30mm centres, rectangular, 9.0% Open Area

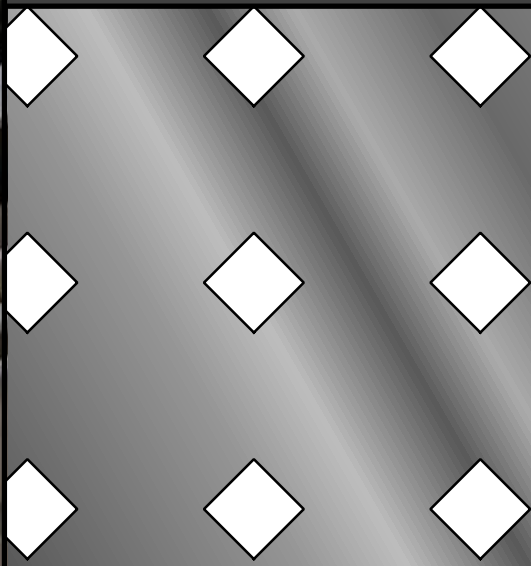
	Material	Sheet Thickness [mm]	
		min.	max.
	Mild Steel	1.0	2.0
	Galvanized Steel	1.0	2.0
	Aluminium	1.0	3.0
	Stainless Steel 304 or 316	NA	NA

ToeToe Rua / V091G18

9.1mm sq diamonds, 30mmx15mm centres, staggered, 18.0% Open Area

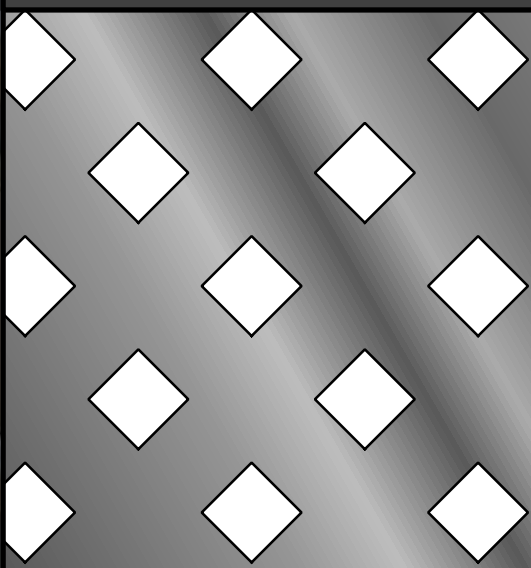
	Material	Sheet Thickness [mm]	
		min.	max.
	Mild Steel	1.0	2.0
	Galvanized Steel	1.0	2.0
	Aluminium	1.0	3.0
	Stainless Steel 304 or 316	NA	NA



Decorative - Ovals



X074S20

7.4x3.9mm ovals, 12.7x8.9mm centres, rectangular, 19.7% Open Area

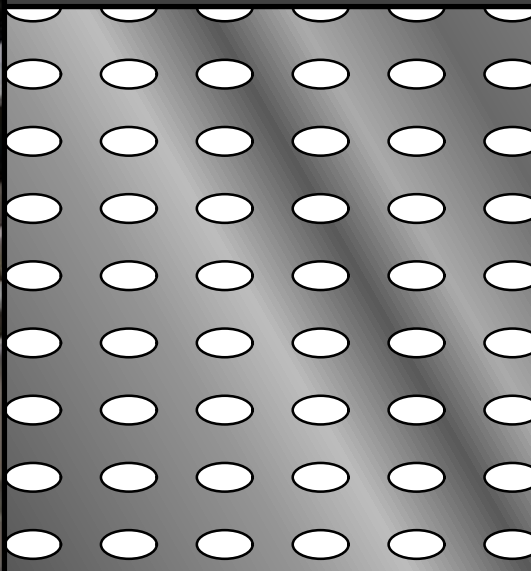
	Material	Sheet Thickness [mm]	
		min.	max.
	Mild Steel	1.2	3.0
	Galvanized Steel	1.2	3.0
	Aluminium	1.2	3.0
	Stainless Steel 304 or 316	1.6	1.6

X087G40

7.4x3.9mm ovals, 12.7x4.5mm centres, staggered, 39.5% Open Area

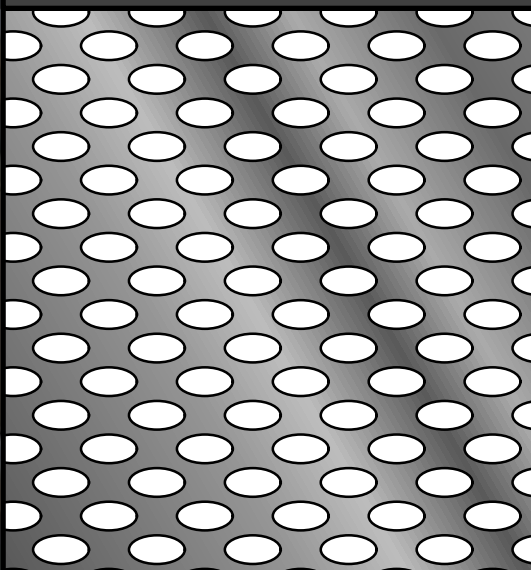
	Material	Sheet Thickness [mm]	
		min.	max.
	Mild Steel	1.2	3.0
	Galvanized Steel	1.2	3.0
	Aluminium	1.2	3.0
	Stainless Steel 304 or 316	1.6	1.6

Custom Perforations

Fielden Engineers are able to work with you to create custom perforations for your specific requirements.

❖ Combining Processes

- ❖ Our range of in-house processes can be combined to manufacture complete products with cutting, punching, forming, folding, fabrication and powder-coating. These can be combined to produce a cost effective result.

❖ Customised Tooling and Special Patterns

- ❖ We can provide customised perforations to suit your requirements. We have a large range of tooling we can utilise/modify to suit your project and create special patterns. We can also design and manufacture custom tooling to increase efficiencies for larger volume work or provide that unique perforation you are looking for.

❖ Picture Perforations and Gradient Perforations

- ❖ We can generate picture perforations and graduated perforations by varying hole sizing and spacing.

❖ Project management

- ❖ In-house design and project management services are available to ensure your project goes to plan.



Special Patterns

We can produce a variety of patterns ideal for architectural spaces as privacy screens, room dividers, balustrade panels or just for decoration.

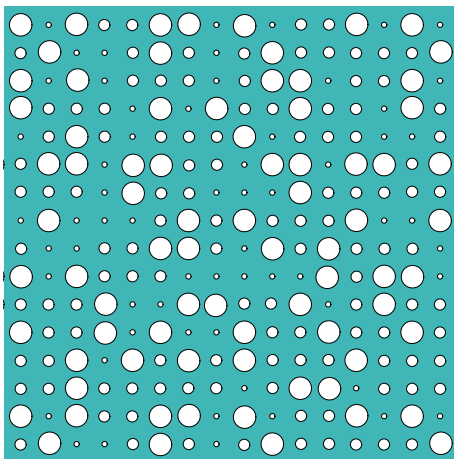

Effervescence
Varied round hole sizes in a rectangular grid

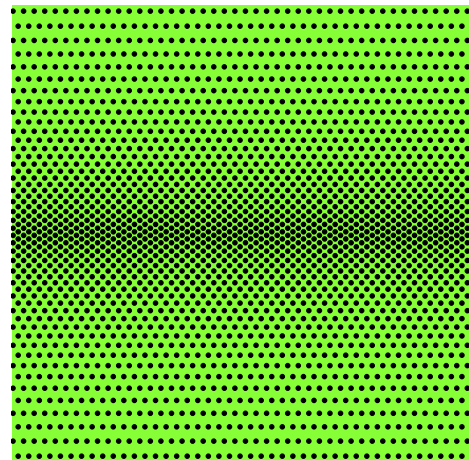

Gradients
We can produce custom patterns with varied hole spacing to create graduated patterns in any shape/size or direction

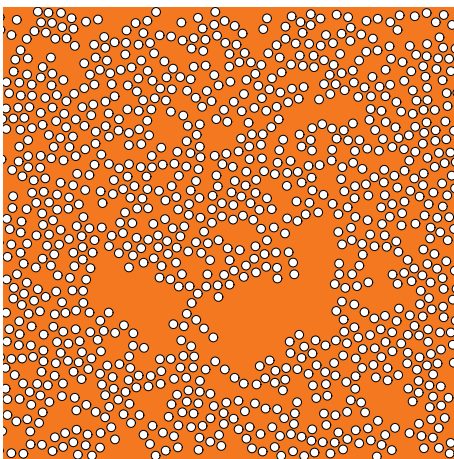

Randomised Patterns
Random patterns utilising any shape can be produced on request

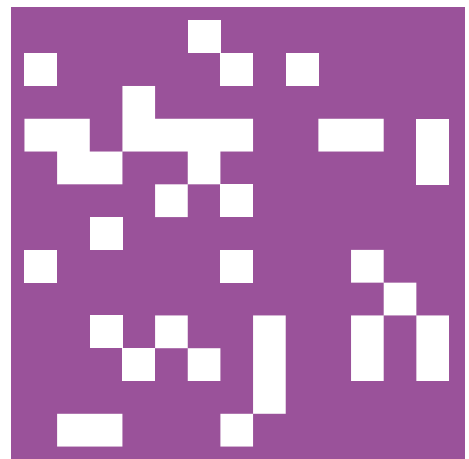

DigiCamo
Using randomised square patterns in a grid pattern mean each panel can be unique

Picture Perforations

We run in-house specialist software to transform your images into perforations of different hole sizes and spacings to create a permanent image in sheet metal.



All we require is a suitable image in a digital format and we can work with you to produce an extraordinary and unique result.



Appendix

Table of Gauges and Weights METRIC

Gauge	Sheet Steel		Galvanized Steel		Stainless Steel		Aluminium	
	mm	kg/m ²	mm	kg/m ²	mm	kg/m ²	mm	kg/m ²
28	0.38	3.05	0.09	0.019	0.40		0.32	0.87
27	0.42	3.36	0.10	0.02	0.44		0.36	0.98
26	0.45	3.66	0.11	0.022	0.47	3.69	0.40	1.09
25	0.53	4.27	0.12	0.025	0.56		0.45	1.24
24	0.61	4.88	0.14	0.028	0.64	4.92	0.51	1.39
23	0.68	5.49	0.15	0.031	0.71		0.57	1.56
22	0.76	6.10	0.17	0.034	0.79	6.15	0.64	1.74
21	0.84	6.71	0.18	0.037	0.87		0.72	1.96
20	0.91	7.32	0.20	0.04	0.95	7.38	0.81	2.21
19	1.06	8.54	0.22	0.046	1.11		0.91	2.48
18	1.21	9.76	0.25	0.052	1.27	9.84	1.02	2.78
17	1.37	10.99	0.28	0.058	1.43		1.15	3.12
16	1.52	12.21	0.31	0.064	1.59	12.30	1.29	3.50
15	1.71	13.73	0.35	0.071	1.79		1.45	3.94
14	1.90	15.26	0.39	0.079	1.98	15.38	1.63	4.42
13	2.28	18.31	0.45	0.093	2.38		1.83	4.96
12	2.66	21.36	0.53	0.108	2.78	21.53	2.05	5.57
11	3.04	24.41	0.60	0.123	3.18	24.61	2.30	6.25
10	3.42	27.46	0.67	0.138	3.57	27.68	2.59	7.02
9	3.80	30.52	0.75	0.153	3.97	0.00	2.91	7.88
8	4.18	33.57	0.82	0.168	4.37	33.84	3.26	8.85

Appendix

Table of Gauges and Weights IMPERIAL

Gauge	Sheet Steel		Galvanized Steel		Stainless Steel		Aluminium	
	in.	Lbs per sq. ft.	in.	Lbs per sq. ft.	in.	Lbs per sq. ft.	in.	Lbs per sq. ft.
28	0.0149	0.625	0.019	0.781	0.0156		0.0126	0.178
27	0.0164	0.688	0.02	0.844	0.0172		0.0142	0.2
26	0.0179	0.75	0.022	0.906	0.0187	0.756	0.0159	0.224
25	0.0209	0.875	0.025	1.031	0.0219		0.0179	0.253
24	0.0239	1	0.028	1.156	0.025	1.008	0.0201	0.284
23	0.0269	1.125	0.031	1.281	0.0281		0.0226	0.319
22	0.0299	1.25	0.034	1.406	0.0312	1.26	0.0253	0.357
21	0.0329	1.375	0.037	1.531	0.0344		0.0285	0.402
20	0.0359	1.5	0.04	1.656	0.0375	1.512	0.032	0.452
19	0.0418	1.75	0.046	1.906	0.0437		0.0359	0.507
18	0.0478	2	0.052	2.156	0.05	2.016	0.0403	0.569
17	0.0538	2.25	0.058	2.406	0.0562		0.0453	0.639
16	0.0598	2.5	0.064	2.656	0.0625	2.52	0.0508	0.717
15	0.0673	2.813	0.071	2.969	0.0703		0.0571	0.806
14	0.0747	3.125	0.079	3.281	0.0781	3.15	0.0641	0.905
13	0.0897	3.75	0.093	3.906	0.0937		0.072	1.016
12	0.1046	4.375	0.108	4.531	0.1094	4.41	0.0808	1.14
11	0.1196	5	0.123	5.156	0.125	5.04	0.0907	1.28
10	0.1345	5.625	0.138	5.781	0.1406	5.67	0.1019	1.438
9	0.1495	6.25	0.153	6.406	0.1562		0.1144	1.614
8	0.1644	6.875	0.168	7.031	0.1719	6.93	0.1285	1.813



Fielden & Sons Ltd
11-23 Columbia Avenue
PO Box 16 450
Hornby, Christchurch, 8441

Phone: +64 3 349 0000
Email: sales@fielden.co.nz
Web: www.fielden.co.nz

Connect with us online...

